



The Warmest Aussie Legend

Coonara Woody



INSTALLATION & OPERATING INSTRUCTIONS

Serial Number of Heater: _____

Coonara WOODHEATERS ARE AUSTRALIAN OWNED AND
MANUFACTURED BY

SHAMIC SHEETMETAL (AUST.) PTY. LTD.

PO BOX 8, KILSYTH, VIC. 3136

PH: 03 9737 5300

<https://shamic.com>

SAVE THESE INSTRUCTIONS

INSTALLATION AND OPERATION INSTRUCTIONS

Have your heater installed by a registered or licensed installer and advise your insurers for inclusion in your household contents policy.

In some states the installer is required to issue a certificate of compliance on the installation; - ensure you obtain this if applicable!

The heater should be checked for scratches/dents prior to installation. Once the heater has been installed scratches or dents may not be covered by warranty.

Coonara Woodheaters should not be modified in any way!

Do not operate the heater with the door open for extended periods.

Always operate with door closed except when lighting or refuelling and maintain all seals in good condition!

Keep children away from the heater when operating! **Coonara Dealers** can advise on heater / door shield accessories for your unit.

WARNING: WHEN IN OPERATION HEATER DOOR GLASS AND SOME DOOR HANDLES MAY BE EXTREMELY HOT! GLOVES SHOULD BE WORN TO TOUCH THESE PARTS.

WARNING: *Coonara* WOODHEATERS AND DEALER SPECIFIED FLUES SHALL BE INSTALLED IN ACCORDANCE WITH THE AUSTRALIAN STANDARD AS 2918 AND THE APPROPRIATE REQUIREMENTS OF THE LOCAL BUILDING REGULATORY AUTHORITY.

WARNING: "BURN ONLY HARDWOOD"

WARNING: DO NOT USE FLAMMABLE LIQUIDS SUCH AS PETROL, KEROSENE, OR ENGINE OIL TO START OR REKINDLE THE FIRE!

CAUTION: MIXING OF APPLIANCE OR FLUE SYSTEM COMPONENTS FROM DIFFERENT SOURCES OR MODIFYING THE DIMENSIONAL SPECIFICATIONS OF COMPONENTS MAY RESULT IN HAZARDOUS CONDITIONS. WHERE SUCH ACTION IS CONSIDERED, THE MANUFACTURER SHOULD BE CONSULTED IN THE FIRST INSTANCE!

CAUTION: THE USE OF SOME TYPES OF PRESERVATIVE TREATED WOOD AS FUEL CAN BE HAZARDOUS (for example: treated radiata pine).

CAUTION: DO NOT STORE FUEL WITHIN THE HEATER INSTALLATION CLEARANCES OR WITHIN THE SPACE REQUIRED FOR FUEL CHARGING OR ASH REMOVAL!

CAUTION: OPEN AIR SLIDE AND TURN FAN OFF BEFORE OPENING DOOR!

DISCLAIMER

The information supplied by this company is our interpretation of AS 2918 and we do not accept responsibility for any errors or omissions.

All **Coonara** Woodheaters have been tested in accordance with and comply to AS 4013.

Please read and thoroughly understand these instructions prior to operating this appliance!
Please store these instructions in a safe place for future reference.

INSTALLATION INSTRUCTIONS (FREESTANDING MODELS ONLY)

The Coonara Woody Free-Standing solid fuel appliance, installed with a Wildcat 6 inch triple flue kit with 8 inch decromesh or solid casing with rear stainless steel flue shield installed between the casing and active flue, conforms to the requirements of the joint AS/NZS 2918:2018 Standard, Appendix B.

Select the position of your heater carefully, taking into consideration all combustible materials in the roof, e.g. ceiling joists, roof trusses, etc.

Floor Protector

A minimum 1055 deep x 1000mm wide a 18mm thick floor protector (compressed board) should be used under and in front of the appliance base when installing the appliance (see joint AS/NDS 2918:2018 3.3.2). The floor protector should extend 520mm in front of the appliance door and be placed centrally in the 1000mm width. The thermal resistivity of the floor protector is 0.08^2 K/W for 6mm thick sheets.

Determine flue location through the ceiling

Position the hearth correctly, and then place the heater on the hearth so that the flue spigot on the heater is correctly aligned with the flue location from the ceiling.

Clearance to combustible surfaces – 8 inch decromesh casing

Position A – Parallel position

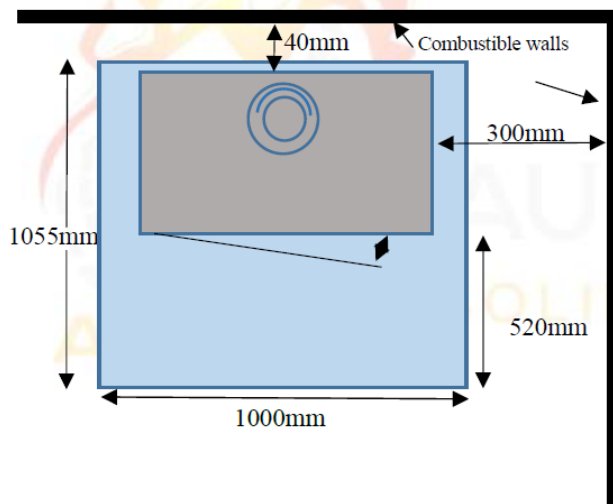

Position B – Corner position

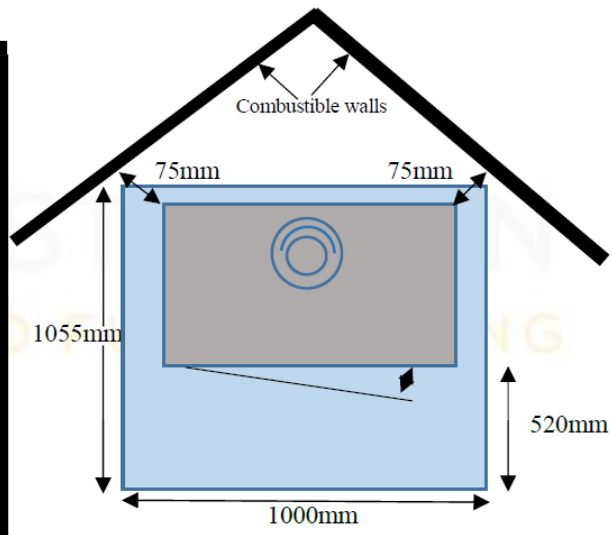

Clearance to combustible surfaces – 8 inch solid casing

Position A – Parallel position

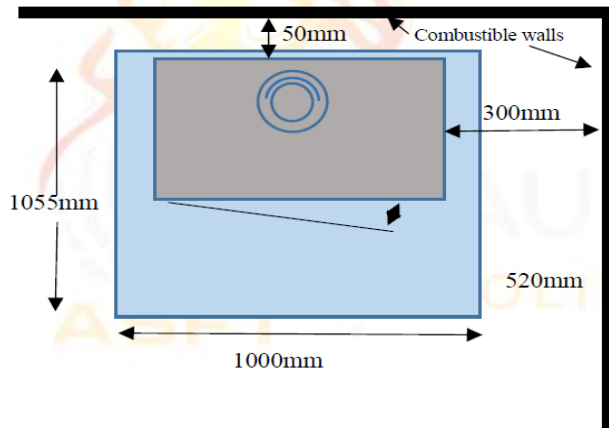

Position B – Corner position

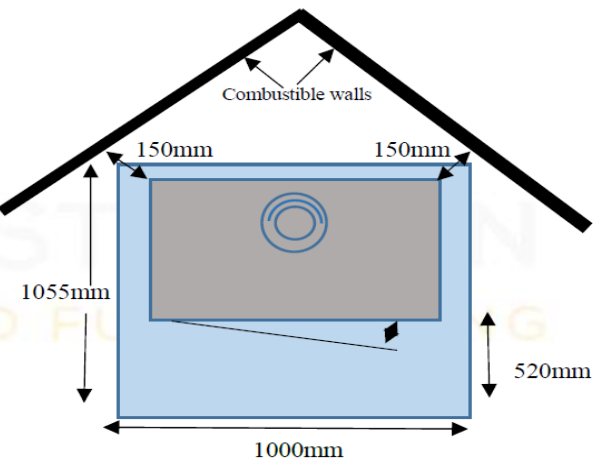

Installing Liners and Grates

1. When you receive your new heater quite a few components are packed in the firebox behind the closed door. Remove the packaging, manuals, front covers, baffle plate and burner tube and from the firebox.
2. The rear plate and bottom grate will be in position in the firebox so leave them in place. The side liners will be sitting on top of the bottom grate, lift them and place them on the sides so the bottom tags engage with the bottom plate and rest on the sides of the firebox.
3. The ashpan is located under the bottom grate and when required can be removed by pulling its handle.
4. Lift the Baffle plate (with the ribs facing downward) into the firebox and onto the Hanger brackets located at the tops of both sides of the firebox. Push the Baffle plate back to ensuring it is hard up against the rear wall of the firebox.
5. Place the secondary air tube onto the hangers such that the hole in the end engages with the pin on the Right Hand Hanger.

The heater is now ready for operation.

FIRST FIRE

YOUR HEATER HAS BEEN SPRAYED WITH HIGH TEMPERATURE PAINT. TO ENSURE THAT THE PAINT IS PROPERLY “CURED IN”, PLEASE FOLLOW THESE STEPS WHEN LIGHTING THE FIRST FIRE IN THE HEATER:

- TURN THE HEATER ON VIA THE REMOTE OR THERMOSTAT, THE DAMPER SHOULD FULLY OPEN AND THE LIGHTS WILL DISPLAY BLUE.
- OPEN THE DOOR AND PLACE A MINIMUM OF 12 PIECES OF DRY KINDLING WOOD ON TOP OF FIRELIGHTERS OR PAPER.
- LIGHT THE FIRE, LEAVING THE DOOR SLIGHTLY OPEN. THIS WILL HELP TO CURE THE PAINT AROUND THE DOOR AND PREVENT THE DOOR SEAL STICKING TO THE FIREBOX. IF THE DOOR SEAL HAPPENS TO COME OUT OF THE DOOR SIMPLY PUSH IT BACK IN. **TO ENSURE THE SAFETY OF YOUR HOME, PLACE A SAFETY SCREEN IN FRONT OF THE HEATER OR STAY NEAR THE FIRE WHILE THE DOOR IS OPEN.**
- WAIT UNTIL THE KINDLING WOOD HAS CAUGHT ON THEN ADD ONE SMALL PIECE OF HARDWOOD.
- LET THAT BURN DOWN TO HOT COAL AND ADD ANOTHER SMALL PIECE OF HARDWOOD.
- AFTER 40 MINUTES CLOSE THE DOOR
- CONTINUE TO ADD ENOUGH WOOD TO MAINTAIN A **SMALL** FIRE
- PLEASE NOTE THAT AS YOU CURE THE FIREBOX THE HEATER WILL PRODUCE AN ODOUR. OPEN A WINDOW OR DOOR TO HELP REDUCE THE SMELL.
- HAVING A SMALLER FIRE WILL HELP CURE THE FIREBOX & THE DOOR ROPE PROPERLY AND WILL ALSO REDUCE THE SMELL OF THE PAINT CURING.
- IT WILL TAKE BETWEEN FOUR TO SIX HOURS TO CURE IN YOUR HEATER.

Operating Information

Fuel

Ignition: A supply of firelighters or newspapers.

Kindling: 10 mm – 20 mm diameter light, split, pieces of dry wood.

Start up wood: 30 mm – 75 mm diameter medium size, split pieces of dry wood.

“BURN ONLY HARDWOOD”

Starting a fire

Turn the heater on using the remote control or the thermostat control (see instructions below).

To build a fire, place firelighters or crumpled balls of newspaper in the firebox and then half fill the firebox with dry kindling.

Light the fire and close the door.

When the kindling is well alight add some start up wood, which will prepare the fire to take larger sized firewood. Close the door and use the remote control or the optional thermostat to control the heater as per the instructions shown below. Continue adding wood to get the fire up to temperature.

Using the Remote Control

1. Turn the heater on by pressing the round button at the top of the remote control. Please note that this remote must be pointed at the heater for operation (same as with your TV).
2. The automatic airslide (that controls the amount of air supplied to the fire, more air results in more heat) will move to the fully open position and the heater will show a blue light, stating the heater is currently 'cold'. The heater will stay in this mode until the fire is established.
3. When the fire heats up and the heaters firebox gets to its minimum operating temperature (50°C), the lights will turn RED and the room fan will automatically turn on to LOW speed.
4. Once the heater is at operational temperature you can control the fan speed via the remotes Fan + and - Buttons.
5. You can also control the airside to adjust the heat output of the heater from the remote controls Flame + and - buttons. The position of the airslide is indicated by the colour of the lights;
 - Red – Airslide fully open and heater operating at Maximum temperature
 - Orange – Airslide mid-way open and heater operating at Average temperature
 - Yellow – Airslide fully closed and heater operating at Minimum temperature

Please note that there is a total of 7 airslide positions between fully open and fully closed. In these midway positions the light will display a combination of the 2 colours either side of its position.

For example: If you have the airslide fully open and the lights are solid Red, a single press on the - Flame button will close the airslide a small amount and the light will begin to change from full red to a slight orange. You can single press the button to 'step' the damper closed or open, or you can hold it down for quicker transitions.

6. To turn the heater off, press the round button at the top of the remote control. If the heater has burnt out it will simply turn off. If the heater is still at operational temperature it will automatically move the airslide to the fully closed Yellow setting and run the fan on Low. Once the fire has burnt out and the firebox drops below the operational temperature, the Heater will automatically turn itself off.

7. Timer Function: If you wish to run your heater at a particular temperature setting before turning off you can use the Timer function. Locate the 'Off Timer' round button at the bottom of the remote control. A single press on this button will put the heater into a mode that will run the heater for 1 hour at the current settings, after which it will then automatically turn off in the same way as Step 6 above. The amount of presses on the button controls the length of Timers delay. i.e. 2 presses = 2 hours, 3 Presses = 3 hours, etc.

Using the Thermostat Control (Optional feature)

1. Turn the Thermostat Remote Control on. Note: This remote does not need to be pointed at the heater for operation.
2. The automatic airside (that controls the amount of air supplied to the fire, more air results in more heat) will move to the fully open position and the heater will show a blue light, stating the heater is currently 'cold'. The heater will stay in this mode until the fire is established.

The heater can be operated in 2 modes, Auto or Manual. Pressing the MODE button on the remote control toggles between these 2 modes and is displayed at the bottom of the remotes LCD display.

Auto Mode

3. Once the fire heats up and the heaters firebox gets to its minimum operating temperature (50°C), the lights will turn RED and the room fan will automatically turn on to LOW speed.
4. Once the heater is at operation temperature you can control your rooms temperature (shown at the top of the display) by setting the desired temperature (shown in the middle of the display) on the remote control. To set the desired temperature press the up▲ and down▼ arrows accordingly.
5. Once the desired temperature is set, the heater will automatically control the fires temperature and the fan speed to regulate its heat output to reach and then maintain the set temperature.

Basic Function explained: When the room temperature drops below the set temperature the automatic airslide will open and the fan speed will increase, once the set temperature is reached the airslide will then begin to close and the fan speed will reduce. Over time the heater will finely tune itself with very small movements of the airslide and by also adjusting the fans speed to hold the room as closely as possible to the set temperature. If you adjust the set temperature up or down the heater will reconfigure itself and over time settle to the set temperature. If the set temperature cannot be reached, the chosen temperature may be out of the capacity of the heater (for your room size), or the fire is not of adequate size. If the fire has burnt down to the point it can no longer maintain the set temperature, the lights will flash Red indicating for the fire to be reloaded with wood.

Manual Mode

6. Once the heater is at operation temperature you can manually control the heat output via the remotes up and down arrows.
7. By pressing the up ▲ arrow you will see the flame displayed on the centre of the screen increase in size and the fan speed increase.

1 = Low, 2 = Medium and 3 = High.

Pressing the down ▼ button will reduce the Flame size and Fan speed.

8. To turn the heater off, press the on/off button on the remote control. If the heater has burnt out it will simply turn off. If the heater is still at operational temperature it will automatically move the airslide to the fully closed Yellow setting and run the fan on Low. Once the fire has burnt out and the firebox drops below the operational temperature, the Heater will automatically turn itself off.

Firebox Loading

When the start-up wood is well alight and the heater is on and at operational temperature, add a larger load of dry firewood.

Your ***Coonara*** heater will burn any diameter logs which fit in the firebox.

Large logs will take longer to ignite but will burn longer.

As well as keeping recommended firewood sizes in mind, the way you load the fuel will affect the operating characteristics of your ***Coonara*** heater. Always ensure adequate air is provided for combustion and, to reduce creosote, a smaller intense fire is preferable to a large smouldering one

If a large log is placed across the width of the firebox, more often than not the wood will smoulder rather than burn effectively. This is because the primary burn air enters the ***Coonara*** firebox above the door opening and travels down the door glass effectively 'washing the glass' (i.e. minimising carbon, soot and creosote deposits), before travelling through the fuel load.

Should the primary burn air intake be restricted in travelling through the fuel load, for example by a large piece of wood lying across the firebox, it follows that the correct combustion process will not take place.

It is better to place 2-3 smaller diameter pieces of wood front to back with a minimum spacing of 20mm as a load and a larger piece or pieces across these.

Reloading

The firebox should be loaded to a minimum of 2/3 full, preferably when the fuel has burnt down to a bed of coals. Attempting to reload part way through a burn period risks smoke, coals, or a log rolling from the heater.

Before reloading, it is important to position the air inlet control to high. Open the door carefully and slowly. Rake over the coals and load the fuel as recommended. After reloading, close the door securely and leave the air inlet fully open on high until the fuel load is well alight. Then the air inlet control can be adjusted to your desired heat output.

Do not throw wood into the firebox

This is an unsafe practice and may dislodge the baffle plate in the heater. It may also cause sparking or dislodge burning wood, which could ignite any combustible materials in the area surrounding the heater (e.g. carpet).

Do not slam the door closed

Wood may be protruding from the firebox and cause the glass to break. It will also diminish the longevity of the door seal.

Preparing for a low (overnight) burn

For an extended low burn ensure a maximum fuel load is placed into the heater, following the reloading procedure outlined previously. The greater the fuel load the longer the burn. After reloading close the door and turn the heater off using the remote control. The heater will automatically run on low mode for as long as the fuel load lasts and will completely shut down if burnt out.

Self cleaning through high firing

It is perfectly normal for the glass door to experience some blackening after extended periods of low burning. High firing helps burn the door glass clean and minimise soot, carbon and creosote formation on the baffle plate and flue as well. High firing can be done daily during the heating season and morning is usually the best time.

Just start or rebuild the fire with the firebox at least 2/3 full, set the air inlet control to high and let the heater operate in this manner for at least 90 minutes.

Replacement parts

Consult your ***Coonara*** Dealer regarding any of the normally replaceable components of the heater i.e. handle, baffle plate, door glass, trivet, door seal and bricks.

Maintenance

Paint surfaces

After the curing process has taken place, little maintenance is required other than dusting off with a cotton cloth. Most marks can be buffed out with a cotton cloth without the need for retouching.

NOTE: Do not use abrasive cleaners or harsh solvents (such as methylated spirits). Should you experience scuffing or scratching, or discolouration due to incomplete curing, the high temperature paint can be touched up and matching spray cans may be purchased from your **Coonara** dealer. To retouch scratches that are down to bare metal, gently sand the surrounding area with 400 wet and dry sandpaper and respray. Remember, if you retouch your **Coonara**, the surface will require curing and may smoke slightly during this process. This is normal.

CAUTION: DO NOT ATTEMPT TO RESPRAY THE HEATER WHILST IT IS IN OPERATION

Door glass

It is usual for creosote and/or smoke deposits to form on the door glass, particularly after an extended period of low burn. Creosote deposits are combustible and can be burnt off through high firing. If any deposits remain, they can be cleaned using any non-abrasive household cleaner. Some experienced users also recommend household vinegar or wet newspaper dipped in the fire ash being most effective. If you experience heavy tar like deposits, then inspect your fuel and review your operating methods. **Wet or green wood** will cause heavy creosote deposits on the glass as well as the flue system and will severely restrict your heaters performance.

WARNING: DO NOT OPERATE THE HEATER IF THE DOOR GLASS IS CRACKED.

Door glass seal

Before lighting the first fire of the heating season, test this seal by opening the firebox door and placing a hand either side of the door glass. Your hands should be positioned together with the glass resting between both palms. Gently try to move the glass around within the doorframe, taking care not to use force. If you can move the glass, consult your **Coonara** dealer as the sealing tape may need replacing.

Door Adjustment

The door is unlikely to become misaligned unless it is knocked and attempts at adjustment may cause rather than solve a problem. Always consult your **Coonara** dealer before attempting any adjustment to the door.

1. Remove door by opening fully and lifting door up off the hinge. (Freestanding models require top panel to be propped up prior to lifting door).
2. Loosen the top & bottom screws securing the door hinge to the front of the firebox upright.
3. Move the hinge left or right as necessary and re-tighten the screws.
4. In some cases, to enable adequate adjustment, it may be necessary to also loosen the centre to relocate the entire hinge.
5. Mark door sealing edge with coloured chalk and close the door. Re-open and check the door is aligned properly via the chalk mark left on the fibreglass door seal of the heater.

NOTE: The door handle may pull the door down on the right-hand side. Compensate for this situation during adjustment.

Flue system

Under normal conditions, and using dry hardwood and correct operating procedures, annual flue maintenance should take place prior to the heating season. If your heater's performance deteriorates, or if it smokes excessively after a trouble-free period of operation, the cause may be creosote. The creosote may have built up to a level where the gases are restricted from exiting the flue pipe because it is partially blocked.

<p>CAUTION: THE FLUE PIPE MUST BE KEPT CLEAN AND IN GOOD CONDITION. ALL SOLID FUEL BURNING APPLIANCES NEED TO BE CLEANED FREQUENTLY BECAUSE SOOT, CREOSOTE AND ASH MAY ACCUMULATE. IN THE EVENT OF A SOOT OR CREOSOTE FIRE IN THE FLUE, IMMEDIATELY CLOSE THE AIR INLET CONTROL TO STARVE THE FIRE OF OXYGEN. IT IS RECOMMENDED THAT YOU CALL THE FIRE BRIGADE FOR FURTHER ASSISTANCE AND ADVICE. WHEN THE FIRE IS OUT, HAVE THE FLUE INSPECTED BY A QUALIFIED INSTALLER TO ENSURE THERE HAS NOT BEEN ANY DAMAGE TO THE FLUE SYSTEM.</p>

For cleaning the flue, you may purchase a flue brush from your **Coonara** dealer, or you can engage the services of a chimney sweep.

Fan

At the end of the heater season you should clean and vacuum the fan and fan tray. Dust and hair can accumulate, especially if you have a pet.



Turn the mains power off and disconnect the power lead from the wall socket.

Console Model

1. To access the fan on console model, remove the six screws from the bottom front panel and put them aside in a safe place.
2. Loosen the four nuts on the support panel that is located behind the bottom front panel and lift it out of the firebox. This allows easy access to the fan and the fan tray. Thoroughly clean the fan and surrounding components to remove all debris, whilst being careful not to apply undue force on hardware or cabling. A vacuum cleaner with a soft brush fitting is best for this job.
3. Once clean, replace the support panel and tighten nuts.
4. Screw the front bottom panel back into position
5. Plug the power lead back into the mains wall socket.

Your fan should now be good to go for another season.

Baffle plate removal

DO NOT USE HEATER IF TOP BAFFLE IS DAMAGED

The baffle plate is held in place by two locating brackets – one on each side of the firebox.

WARNING: ALLOW THE HEATER TO COOL IF HOT BEFORE ATTEMPTING BAFFLE PLATE REMOVAL.

Cast Iron Baffles

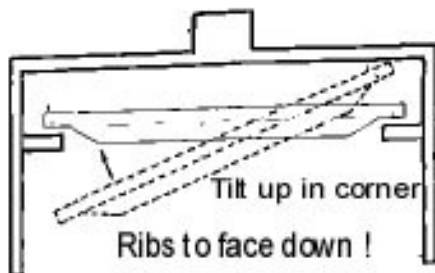

1. Remove secondary air tube where fitted.
2. Lift one side of the baffle upwards; lower other side towards the base clearing the support brackets and pull forward.
3. Reverse procedure to replace baffle.

NOTE: "RIBS" on the baffle plate to face downwards.

The baffle plate should be removed and inspected annually, and flaky deposits shaken or brushed off. The most convenient time to maintain the baffle is when the flue is being cleaned.

TABLE 1: FIREWOOD SPECIES AND THEIR PROPERTIES

Firewood Species	Forest Type	Heat Avail. Per Unit Volume (%)	Density (Dry Air) lb/ft3/ Kg/m3	Splitting	Ignitability	Coals	Sparks	Avail.
Mallee Roots	Mallee	100	N.A	Difficult	Poor	Excellent	Few	Good
Belah, Buloke	Mallee Box-Ironbark	100	70 / 1121	Good	Poor	Excellent	Few	Limited
Grey Box	Box-Ironbark	100	70 / 1121	Difficult	Poor	Excellent	Few	Good
Black Box	Box-Ironbark	97	69 / 1105	Difficult	Poor	Excellent	Few	Limited
Red Ironbark	Box-Ironbark	97	69 / 1105	Difficult	Poor	Excellent	Few	Good
Yellow Box	Box-Ironbark	91	65 / 1041	Difficult	Poor	Excellent	Few	Good
Red Box	Box-Ironbark	91	67 / 1073	Difficult	Poor	Excellent	Few	Good
Yellow Gum	Box-Ironbark	90	60 / 993	Difficult	Poor	Excellent	Few	Good
River Red Gum	River Red Gum	80	56 / 897	Difficult	Poor	Excellent	Moderate	Good
Blue Gum	Foothill	80	61 / 977	Fair	Fair	Good	Few	Good
Red Stringy Bark	Foothill	72	54 / 865	Good	Good	Good	Few	Good
Messmate	Foothill	68	45 / 721	Good	Good	Good	Few	Good
Mountain Ash	Mountain	53	42 / 673	Excellent	Excellent	Fair	Moderate	Good
White Cypress Pine	Box-Ironbark	60	42 / 673	Good	Excellent	Poor	Many	Limited
Radiata Pine	Foothill Plantations	45	32 / 512	Fair	Excellent	Poor	Many	Good

KNOW YOUR WOOD

A piece of dry wood produces an incredible amount of heat when burnt correctly. A piece of dry wood however is also like a sponge and can absorb up to 70% of its weight in water if exposed to the elements.

The fact that all wood heaters rely on dry fuel to perform at their best cannot be over-emphasized as it is critical to your heater’s performance. The relevant moisture content (wetness) of wood is indicated in the following table.

Moisture Content	Fuel Suitability
Below 10%	Very dry. Wood burns but less efficiently as some moisture is needed for ideal combustion.
10% - 18%	Ideal. Wood burns efficiently and economically
18% - 25%	Wood will burn, but less efficiently
Above 25 %	Wood too wet to burn efficiently

It is extremely difficult to light, let alone maintain, a fire using wet or green wood. A firebox filled with 20kg, wet or green wood could contain up to 10 litres of water. As a result, the heater would naturally perform very poorly as most of the heat generated would be directed to vaporizing the water. Be aware that if you purchase wood with 50% moisture content, the 50% of the money you paid for the wood, in fact, purchased water.

Ideally, firewood should be organised in the spring and under cover by mid-autumn. If you obtain next year’s wood in spring, it should be open air dried over summer for a minimum of six months. The wood should then be stacked under cover in such a way that air can flow between the pieces. A plastic sheet or tarpaulin is not sufficient as condensation may account for a high moisture content in the wood.

It is important to select firewood that will build a good base or bed of coals. It is actually the coals and not the flames, which form the hottest part of the fire and provide the heat source for your heater.

Dry hardwood has over twice the density of pine, so double the volume of pine is required to provide the same amount of heat. Firewood that has had the bark removed produces less ash. The table above provides a good indication of the properties of various common type of firewood.

How to Make a Warranty Claim

Coonara, Heatcharm and Arrow Heaters.

The full Warranty Statement for your heater is contained in the Installation and Operating Instructions booklet that was provided with the product.

1. Check the details of the warranty statement
2. Determine if you think the problem is covered by warranty
3. Ensure that you have proof of purchase
4. Contact the retailer that sold you the heater
5. Advise them of the specific problem
6. Provide the details that your retailer requests to complete a Warranty Claim Form. This must include the heater model, serial number and installation compliance certificate, if applicable in your State.
7. Your retailer will forward your claim to Shamic Sheetmetal (Aust) Pty Ltd, the manufacturer of the above heater brands
8. Shamic will contact you to acknowledge that they have received the claim, if the claim has been accepted and the next steps involved in fixing the problem
9. Parts and/or service is provided
10. Contact your retailer if the problem has not been fixed.

COONARA WOODHEATERS WARRANTY – CONSOLE & INBUILT MODELS

DESIGNATION OF WARRANTOR. This warranty is extended by Shamic Sheetmetal (Aust) Pty. Ltd with respect to Coonara woodheaters **PRODUCT.** This Coonara heater is comprised of the heater proper (including components and firebox), fan assembly, speed control switch, electrical components, firebricks, seals and moving parts. Except where specifically excluded from coverage hereunder, this warranty covers all components designed. See **exclusions and qualifications** below for further information on product coverage.

WARRANTY:

- 1) Shamic Sheetmetal (Aust) Pty. Ltd, warrants the firebox to be free of defects in materials and workmanship of a period of ten (10) years from the date of purchase.
- 2) Shamic Sheetmetal (Aust.) Pty.Ltd., warrants that all other components of the unit to be free of defects in material and workmanship for a period of one (1) year from date of purchase, excluding door glass.
- 3) If this Coonara heater is found to be defective in material or workmanship Shamic will repair or replace such defects in the Coonara heater at Shamic's option in accordance with Coonara's warranty policy during the period on this warranty. If the defect is found not to meet the Consumer Guarantee requirements and constitutes a major failure, the purchaser may be able to choose to repair or replace the defective heater or part or obtain a refund.
- 4) **Exclusions and qualifications.** This warranty is subject to the following exclusions and qualifications.
 - a) This warranty extends only to the original consumer purchaser, who has purchased the heater from an authorised Coonara dealer.
 - b) This warranty does not apply to, and Coonara assumes no responsibility for any damages that result due to, installation or operation of the heater not in accordance with both the installation and operation instructions furnished with the unit.
 - c) This Warranty does not cover any damage caused by water from any source
 - d) This warranty does not apply to any heater which has been modified or damaged in shipping or by improper handling, improper operation, abuse, misuse, accident or unworkmanlike repairs.
 - e) Shamic Sheetmetal (Aust.) Pty.Ltd. does not warrant the structural performance of the heater when fuel products with abnormal burning characteristics, including but not limited to synthetic logs, coal, wood treated with flammable liquid, logs made from pressed wood, driftwood or any materials containing salt or corrosives, rubbish or garbage are used. Flammable liquid fuels are explosive and should never be used in this product.
 - f) Shamic Sheetmetal (Aust.) Pty.Ltd. expressly excludes any liability hereunder for defects or damage caused by the installation or of any components not expressly authorised and approved by Shamic. Shamic further assumes no liability for defects or damage caused by any modification not expressly authorised and approved by Shamic. Unauthorised components or modifications could create a fire hazard by altering the safety design of the heater.
 - g) Building Codes. Since building code requirements vary, users should determine in advance whether there are any building code restrictions on the installation or use of the heater. Shamic makes no representation of warranty regarding building code compliance and shall not be responsible for compliance therewith.
 - h) Shamic will only accept claims under this warranty in strict accordance with the conditions set out below.
- 5) Shamic Sheetmetal (Aust.) Pty.Ltd. shall not be liable for any breakages of glass components, transit damage or, where it can be shown that the consumer guarantee obligations as the manufacturer have been met, for any claim by any person for incidental or consequential damages caused by defects in the Coonara heater. Whether such damage occurs or is discovered before or after replacement or repair, and whether or not such damage is caused by Coonara negligence. Normal wear and tear items such as routine surface maintenance, door ropes, seals and door glass are also excluded from this warranty.
- 6) Shamic goods come with guarantees that cannot be excluded under Australian Consumer Law. The purchaser is entitled to a replacement or a refund for a major failure and compensation for any reasonably foreseeable loss or damage. The purchaser is also entitled to have the goods repaired or replaced if the goods fail to be of acceptable quality and the failure does not amount to a major failure.
- 7) This warranty applies only to units purchased from an authorised dealer and the duration of this implied warranty, including merchantability, applicable to this Coonara heater is limited to the duration of the foregoing warranty.
- 8) Before Shamic Sheetmetal (Aust.) Pty.Ltd. will recognise or accept a claim under this warranty, you must provide proof of purchase. On purchase of the heater, despatch your warranty card to Shamic Sheetmetal (Aust.) Pty.Ltd.
- 9) Your authorised dealer must be notified of any defect in the heater, for investigation of the claim. Your authorised dealer will be able to explain the process of making a warranty claim and any costs associated with returning goods. In the event where a remedy is necessary and the claims under warranty are accepted, the purchaser may be required to return the goods to the authorised dealer for repair, replacement or refund.



DETACH AND RETURN BY MAIL

WOODHEATER BY SHAMIC SHEETMETAL (AUST) P/L
PO BOX 8 KILSYTH, VIC. 3137
Ph: 03 9737 5300
Email: info@shamic.com.au



NAME _____

ADDRESS _____

CITY / STATE / POSTCODE _____

PURCHASED AT (Dealer name & address) _____

DATE PURCHASED _____ MODEL _____ SERIAL NO _____

WHERE DID YOU HEAR ABOUT COONARA WOODHEATERS? RADIO, TELEVISION, NEWSPAPER, DEALER, WEBSITE, OTHER - Please provide details.