



COONARA

The Warmest Aussie Legend

SETTLER C500



SETTLER 500 SERIES

SETTLER 1500



SETTLER RANCH



INSTALLATION & OPERATING INSTRUCTIONS

Serial Number of Heater: _____ Model: _____

SETTLER WOODHEATERS ARE AUSTRALIAN OWNED & MANUFACTURED
BY

SHAMIC SHEETMETAL (AUST.) PTY. LTD.

PO BOX 8, KILSYTH, VIC. 3136

PH: 03 9737 5300

<https://shamic.com>

SAVE THESE INSTRUCTIONS

INSTALLATION AND OPERATION INSTRUCTIONS

Have your heater installed by a registered or licensed installer, and advise your insurers for inclusion in your household contents policy.

In some states the installer is required to issue a certificate of compliance on the installation; - ensure you obtain this if applicable!

SETTLER Woodheaters should not be modified in any way!

Do not operate the heater with the door open for extended periods.

Always operate with door closed except when lighting or refuelling, and maintain all seals in good condition!

Keep children away from the heater when operating! **SETTLER** Dealers can advise on heater / door shield accessories for your unit.

WARNING: When in operation heater door glass is extremely hot!

WARNING: **SETTLER** WOODHEATERS AND DEALER SPECIFIED FLUES SHALL BE INSTALLED IN ACCORDANCE WITH THE AUSTRALIAN STANDARD AS 2918 AND THE APPROPRIATE REQUIREMENTS OF THE LOCAL BUILDING REGULATORY AUTHORITY.

WARNING: DO NOT USE FLAMMABLE LIQUIDS SUCH AS PETROL, KEROSENE, OR ENGINE OIL TO START OR REKINDLE THE FIRE!

WARNING: "BURN ONLY HARDWOOD"

CAUTION: MIXING OF APPLIANCE OR FLUE SYSTEM COMPONENTS FROM DIFFERENT SOURCES OR MODIFYING THE DIMENSIONAL SPECIFICATIONS OF COMPONENTS MAY RESULT IN HAZARDOUS CONDITIONS. WHERE SUCH ACTION IS CONSIDERED, THE MANUFACTURER SHOULD BE CONSULTED IN THE FIRST INSTANCE!

CAUTION: THE USE OF SOME TYPES OF PRESERVATIVE TREATED WOOD AS FUEL CAN BE HAZARDOUS (for example: treated radiata pine).

CAUTION: DO NOT STORE FUEL WITHIN THE HEATER INSTALLATION CLEARANCES OR WITHIN THE SPACE REQUIRED FOR FUEL CHARGING OR ASH REMOVAL!

CAUTION: OPEN AIR SLIDE AND TURN FAN OFF BEFORE OPENING DOOR!

DISCLAIMER

The information supplied by this company is our interpretation of AS 2918 and we do not accept responsibility for any errors or omissions.

All **SETTLER** Woodheaters have been tested in accordance with and comply to AS 4013.

Please read and thoroughly understand these instructions prior to operating this appliance!
Please store these instructions in a safe place for future reference.

INSTALLATION INSTRUCTIONS (FREESTANDING MODELS ONLY)

Select the position of your heater carefully, taking into consideration all combustible materials in the roof; eg. ceiling joists, roof trusses, etc.

Determine flue location through the ceiling:

Position the hearth correctly, then place the heater on the hearth so that the flue spigot on the heater is correctly aligned with the flue location from the ceiling.

This heater has been tested and approved to AS 2918 using a standard, default triple skin Flue Kit.

Clearance to combustible surfaces:

(Ensure correct model)

Dimensions in mm

Minimum distance <i>Millimetres</i>	Reference Symbol	Settler C500 & Ranch
Standard Installation	A (Rear Wall)	200 or 75 see below
	B (Side Wall)	230
Corner Installation	C	50

A minimum 861mm deep x 871 mm wide by 9mm thick floor protector (Bellis board or similar) must be used under and in front of the appliance base when installing the appliance. The floor protector must be installed so that its leading edge is a minimum of 375mm in front of the appliance base. The thermal resistivity of the floor protector should be a minimum of 0.1m².K/W for 9mm thick sheets.

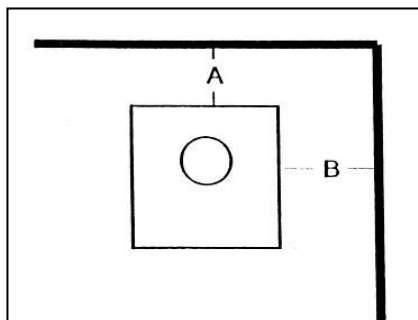

Standard Installation

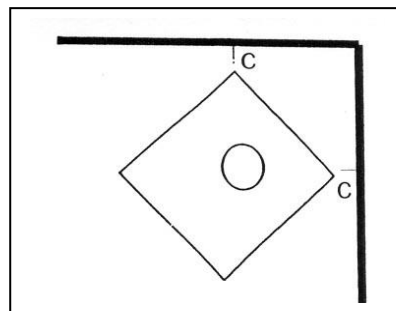

Corner Installation

200 or 75mm when installed with and additional 900mm x 160° stainless steel shield between first length of active flue above the spigot and decromesh casing

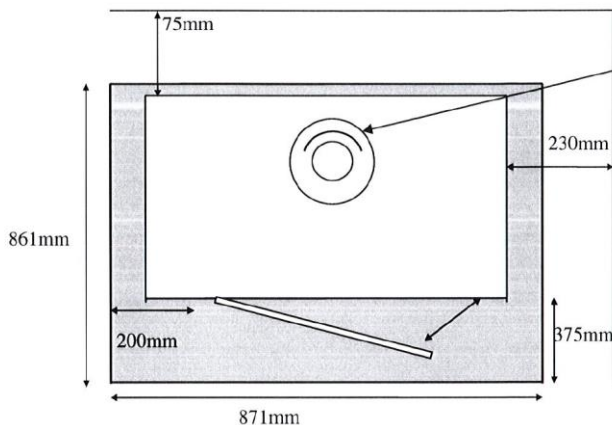

Position A

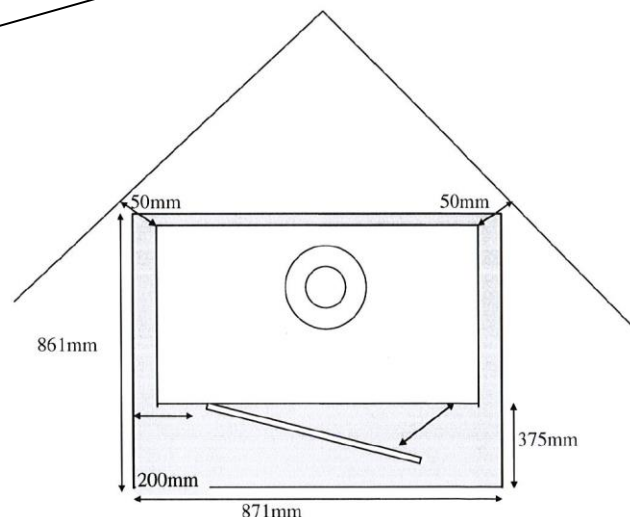

Position C

INSTALLATION OF FIREPLACE - INSERT MODELS (without zero clearance box.)

The heater must only be installed in either a sound concrete or masonry fireplace, connected to a chimney, both of which must be inspected for soundness and thoroughly cleaned before the heater is installed, **or** the **Shamir** tested and approved Zero Clearance Heater Casing unit in conjunction with a standard, default triple skin flue system.

Floor Protection:

- Floor protection of a minimum 570mm deep x 635mm wide x 90mm thick masonry brick (or material of equivalent or greater thermal resistance) must be used under the appliance
- Floor protection of a minimum 400mm deep x 870mm wide x 90mm thick masonry brick (or material of equivalent or greater thermal resistance) must be used in front of the appliance.

Note: The floor protection/hearth must have thermal resistance of 0.4m². K/W or greater.

Clearances:

For concrete or masonry fireplaces the following clearances and instructions apply:

After removing the packaging, slide the heater into the fireplace opening. A flue system must be connected to the heater, providing free and effective discharge of combustion by-products outside the building and any enclosed or confined space.

The stainless steel ring (supplied with the heater) must be fitted to the flue spigot of all inbuilt models for correct location of the flue.

		<i>Minimum Dimensions mm</i>
Minimum distance:	Models:	Settler 1500
From the appliance base to the underside of the mantle shelf		1150
From the appliance base to the first combustible above the appliance (mantle key or cross member)		900
Floor Protector/Hearth to extend from the front of the appliance base		400
Floor Protector/Hearth width (in front of the appliance base)		870

Note: The mantle shelf must not extend further than 250mm from the wall into the room. The mantle uprights must be at least 20mm away from the side of appliance face and must be less than 60mm deep.

Note: the first 300mm of wall above the appliance front must be made of a non combustible material.

Note: The floor protection/hearth must have thermal resistance of 0.4m². K/W or greater

Note: The fireplace cavity must be sufficient to accommodate the external firebox dimension with a minimum clearance of 25 mm all around.

Note: The power cord may be relocated from the right-hand front side of the heater to the left-hand side. This procedure must only be carried out by a licensed electrical contractor.

Installation using the Shamic Zero Clearance Box

A minimum 595mm deep x 950mm wide x 12mm thick floor protector (compressed board) should be used under the appliance, a minimum 875mm wide x 620mm deep x 18mm thick floor protector (compressed board) must be used in front of the appliance base when installing the appliance (see joint AS/NZS 2918:2018 3.3.2). The floor protector should extend 560mm in front of the appliance zero clearance box and be placed centrally in the 875mm width. The Thermal resistivity of the floor protector is 0.08m².K/W for 18mm thick compressed cement sheets.

The appliance and Flue Combination should be installed at the following clearances;

- Venting in the ceiling of the enclosure around the outer triple flue skin must be a minimum of 267,850mm² , evenly spaced around the outer casing.
- The outer casing of the flue (10¼") must be vented into the zero clearance box outer skin and be sealed to prevent venting into the enclosure.
- The inner galvanised casing of the flue (8¼") must be vented into the zero clearance box inner skin and be sealed to prevent venting into the enclosure.
- The front wall of the enclosure must be made of non-combustible material to a height of 200mm above the zero box and must extend to 100mm either side of the zero clearance box.
- 200mm from the top of the zero clearance box to the first internal wall noggin, the noggin must be a minimum of 35mm from the flue outer casing.
- The rear Combustible wall of the enclosure must be no closer than 25mm from the rear of the appliance zero clearance box.
- The side combustible wall of the enclosure must be no closure than 25mm from the side of the appliance zero clearance box.
- Underside mantle shelf shall be no closer than 440mm from the top of the appliance hot air outlet, the mantle shelf shall extend no further than 250mm into the room.
- Underside mantle key shall be no closer than 390mm from the top of the appliance hot air outlet, the mantle key shall extend no further than 25mm into the room.
- Mantle uprights shall be no closer than 15mm from the side of the appliance fascia and the mantle uprights shall be no thicker than 70mm.

Refer to the installation diagram on the next page.

Installation Diagram – Zero Clearance Box

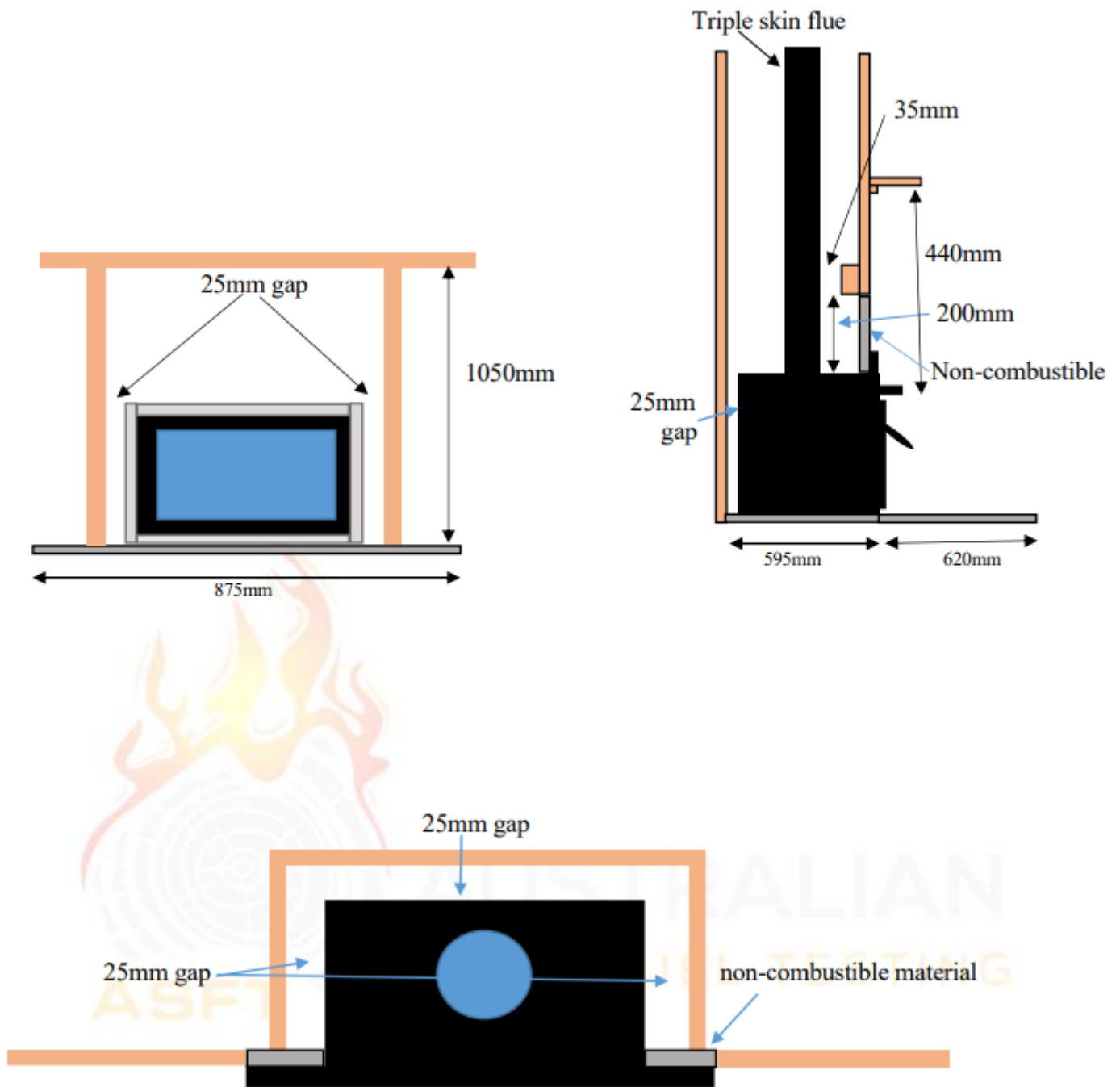

The Coonara Settler I500 Inbuilt and Zero Clearance box solid fuel appliance installed into a zero clearance enclosure conforms to the requirements of the joint AS/NZS 2918:2018 Standard, Appendix B.

Firebox Internal Set Up

Step 1. Install the top baffle plate, place both hands underneath the plate lift either the right or left hand side of the plate up so it is on an angle. Lift up over the locating tab on the side of the firebox then lift up the other side and push the plate to the back of the firebox. **PLEASE MAKE SURE THE RIBS ON THE BAFFLE PLATE ARE FACING DOWN.**

Step 2. Install the secondary air tube, in front of the baffle plate you will see a channel on each side of the firebox, lift the burn tube up into place ensuring it is sitting in the channel with the **holes facing down.**

Step 3. Install the rear and side liners, for the **500** you will have a **one piece** rear liner, for the **600** you will have a **2 piece** rear liner. Put your rear liner or liners into the back of the firebox then put in your side liners in to hold the rear liner or liners in place. **Make sure the smooth side of the liners are up against the firebox and the ribs are facing into the firebox running horizontally.**

Step 4. Install bottom firebricks, install the 4 firebricks horizontally into the bottom of the firebox.

*****Please note when cleaning your ash out of your heater leave an inch of ash over the top of your firebricks*****

DO NOT USE HEATER IF TOP BAFFLE OR LINERS ARE DAMAGED

FIRST FIRE

YOUR HEATER HAS BEEN SPRAYED WITH HIGH TEMPERATURE PAINT. TO ENSURE THAT THE PAINT IS PROPERLY “CURED IN”, PLEASE FOLLOW THESE STEPS WHEN LIGHTING THE FIRST FIRE IN THE HEATER:

- ENSURE THE AIR CONTROL SLIDE IS FULLY OPEN.
- OPEN THE DOOR AND PLACE A MINIMUM OF 12 PIECES OF DRY KINDLING WOOD ON TOP OF FIRELIGHTERS OR PAPER.
- LIGHT THE FIRE, LEAVING THE DOOR SLIGHTLY OPEN. THIS WILL HELP TO CURE THE PAINT AROUND THE DOOR AND PREVENT THE DOOR SEAL STICKING TO THE FIREBOX. IF THE DOOR SEAL HAPPENS TO COME OUT OF THE DOOR SIMPLY PUSH IT BACK IN. **TO ENSURE THE SAFETY OF YOUR HOME, PLACE A SAFETY SCREEN IN FRONT OF THE HEATER OR STAY NEAR THE FIRE WHILE THE DOOR IS OPEN.**
- WAIT UNTIL THE KINDLING WOOD HAS CAUGHT ON THEN ADD ONE SMALL PIECE OF HARDWOOD.
- LET THAT BURN DOWN TO HOT COAL AND ADD ANOTHER SMALL PIECE OF HARDWOOD.
- AFTER 40 MINUTES CLOSE THE DOOR, SET THE AIR CONTROL TO HALFWAY AND TURN THE FAN ON TO THE LOW SETTING.
- CONTINUE TO ADD ENOUGH WOOD TO MAINTAIN A SMALL FIRE
- PLEASE NOTE THAT AS YOU CURE THE FIREBOX THE HEATER WILL PRODUCE AN ODOUR. OPEN A WINDOW OR DOOR TO HELP REDUCE THE SMELL.
- HAVING A SMALLER FIRE WILL HELP CURE THE FIREBOX & THE DOOR ROPE PROPERLY AND WILL ALSO REDUCE THE SMELL OF THE PAINT CURING.
- IT WILL TAKE BETWEEN FOUR TO SIX HOURS TO CURE IN YOUR HEATER.

Operating Information

Fuel

Ignition: A supply of firelighters or newspapers.

Kindling: 10 mm – 20 mm diameter light, split, pieces of dry wood.

Start up wood: 30 mm – 75 mm diameter medium size, split pieces of dry wood.

“BURN ONLY HARDWOOD”

Starting a fire

Fully open the air slide, lift the door handle upward and open the door slowly.

To build a fire, place firelighters or crumpled balls of newspaper in the firebox. Half fill the firebox with dry kindling.

Light the fire and close the door.

When the kindling is well alight add some start up wood, which will prepare the fire to take larger sized firewood.

Switch on the fan after the firebox has heated up. (This could take up to 30 minutes).

Loading

When the start up wood is well alight add a load of dry firewood.

Your *Coonara* heater will burn any diameter logs which fit in the firebox.

Large logs will take longer to ignite but will burn longer.

Once these logs are alight, adjust the air control to the desired level.

As well as keeping recommended firewood sizes in mind, the way you load the fuel will affect the operating characteristics of your *Coonara* heater. Always ensure adequate air is provided for combustion and, to reduce creosote, a smaller intense fire is preferable to a large smouldering one.

If a large log is placed across the width of the firebox, more often than not the wood will smoulder rather than burn effectively. This is because the primary burn air enters the *Coonara* firebox above the door opening and travels down the door glass effectively ‘washing the glass’ (i.e. minimising carbon, soot and creosote deposits), before travelling through the fuel load.

Should the primary burn air intake be restricted in travelling through the fuel load, for example by a large piece of wood lying across the firebox, it follows that the correct combustion process will not take place.

It is better to place 2-3 smaller diameter pieces of wood front to back with a minimum spacing of 20mm as a load and a larger piece or pieces across these.

Note: The fan fitted to the heater should be operating whenever a fire is burning (except on start up). Failure to do so may overheat the unit and void warranty.

Use of the fan

Coonara heaters are fitted with a 3-speed fan for efficient distribution of warmth.

Operating the fan in your wood heater is critical at all stages of use except at startup, where the follow steps apply:

- When the fire has been underway for 30 minutes turn the fan on to low
- Once the fire is established, increase the fan speed to medium to heat the room
- Once the desired room temperature has been reached, turn the fan back to low
- **DO NOT TURN THE FAN OFF** at any time during the burning period
- The fan should remain on during overnight burns.

Note

The use of the fan is critical to removing the hot air generated by the fire into the space to be heated. This is called convection heat, compared to other types of wood heaters which are designed to heat up the fireplace and provide radiant heat. The objective of your wood heater is to heat the room, not the fireplace.

The use of the fan on high speed (3) is OK for a short period if required, but if the air is driven too quickly through the system it does not have sufficient time to gather heat before being expelled through the vents.

The cost of running the fan while using the heater is negligible compared to the air pollution caused by inefficient burning as well as the potential damage to baffles, seals, glass and the integrity (buckling) of the steel firebox that may be caused by producing heat without an effective outlet via the fan.

Generally, an established fire should warm the required area with the fan on the low setting.

Reloading

The firebox should be loaded to a minimum of 2/3 full, preferably when the fuel has burnt down to a bed of coals. Attempting to reload part way through a burn period risks smoke, coals, or a log rolling from the heater.

Before reloading, it is important to position the air inlet control to high. Open the door carefully and slowly. Rake over the coals and load the fuel as recommended. After reloading, close the door securely and leave the air inlet fully open on high until the fuel load is well alight. Then the air inlet control can be adjusted to your desired heat output.

Do not throw wood into the firebox

This is an unsafe practice and may dislodge the baffle plate in the heater. It may also cause sparking or dislodge burning wood, which could ignite any combustible materials in the area surrounding the heater (e.g. carpet).

Do not slam the door closed

Wood may be protruding from the firebox and cause the glass to break. It will also diminish the longevity of the door seal.

Preparing for a low (overnight) burn

For an extended low burn ensure a maximum fuel load is placed into the heater, following the reloading procedure outlined previously. The greater the fuel load the longer the burn. After reloading close the door and leave the air inlet fully open (high) until the load is alight. The air inlet should then be turned down to the low setting.

The optimum air flow setting to achieve an overnight burn may vary for different reasons. Experiment to find the best result.

The fan should remain on low setting during overnight burns.

Self cleaning through high firing

It is perfectly normal for the glass door to experience some blackening after extended periods of low burning. High firing helps burn the door glass clean and minimise soot, carbon and creosote formation on the baffle plate and flue as well. High firing can be done daily during the heating season and morning is usually the best time.

Just start or rebuild the fire with the firebox at least 2/3 full, set the air inlet control to high and let the heater operate in this manner for at least 90 minutes.

Replacement parts

Consult your *Coonara* Dealer regarding any of the normally replaceable components of the heater i.e. handle, baffle plate, cast iron liners, door glass, fans, door seal and bricks.

Maintenance

Paint surfaces

After the curing process has taken place, little maintenance is required other than dusting off with a cotton cloth. Most marks can be buffed out with a cotton cloth without the need for retouching.

NOTE: Do not use abrasive cleaners or harsh solvents (such as methylated spirits). Should you experience scuffing or scratching, or discolouration due to incomplete curing, the high temperature paint can be touched up and matching spray cans may be purchased from your **Coonara** dealer. To retouch scratches that are down to bare metal, gently sand the surrounding area with 400 wet and dry sandpaper and respray. Remember, if you retouch your **Coonara**, the surface will require curing and may smoke slightly during this process. This is normal.

CAUTION: DO NOT ATTEMPT TO RESPRAY THE HEATER WHILST IT IS IN OPERATION

Door glass

It is usual for creosote and/or smoke deposits to form on the door glass, particularly after an extended period of low burn. Creosote deposits are combustible and can be burnt off through high firing. If any deposits remain, they can be cleaned using any non-abrasive household cleaner. Some experienced users also recommend household vinegar or wet newspaper dipped in the fire ash being most effective. If you experience heavy tar like deposits, then inspect your fuel and review your operating methods. **Wet or green wood** will cause heavy creosote deposits on the glass as well as the flue system and will severely restrict your heaters performance.

WARNING: DO NOT OPERATE THE HEATER IF THE DOOR GLASS IS CRACKED.

Door glass seal

Before lighting the first fire of the heating season, test this seal by opening the firebox door and placing a hand either side of the door glass. Your hands should be positioned together with the glass resting between both palms. Gently try to move the glass around within the doorframe, taking care not to use force. If you can move the glass, consult your **Coonara** dealer as the sealing tape may need replacing.

Door Adjustment

The door is unlikely to become misaligned unless it is knocked and attempts at adjustment may cause rather than solve a problem. Always consult your **Coonara** dealer before attempting any adjustment to the door.

1. Remove door by opening fully and lifting door up off the hinge. (Freestanding models require top panel to be propped up prior to lifting door).
2. Loosen the top & bottom screws securing the door hinge to the front of the firebox upright.
3. Move the hinge left or right as necessary and re-tighten the screws.
4. In some cases, to enable adequate adjustment, it may be necessary to also loosen the centre to relocate the entire hinge.
5. Mark door sealing edge with coloured chalk and close the door. Re-open and check the door is aligned properly via the chalk mark left on the fibreglass door seal of the heater.

NOTE: The door handle may pull the door down on the right-hand side. Compensate for this situation during adjustment.

Flue system

Under normal conditions, and using dry hardwood and correct operating procedures, annual flue maintenance should take place prior to the heating season. If your heater's performance deteriorates, or if it smokes excessively after a trouble-free period of operation, the cause may be creosote. The creosote may have built up to a level where the gases are restricted from exiting the flue pipe because it is partially blocked.

<p>CAUTION: THE FLUE PIPE MUST BE KEPT CLEAN AND IN GOOD CONDITION. ALL SOLID FUEL BURNING APPLIANCES NEED TO BE CLEANED FREQUENTLY BECAUSE SOOT, CREOSOTE AND ASH MAY ACCUMULATE. IN THE EVENT OF A SOOT OR CREOSOTE FIRE IN THE FLUE, IMMEDIATELY CLOSE THE AIR INLET CONTROL TO STARVE THE FIRE OF OXYGEN. IT IS RECOMMENDED THAT YOU CALL THE FIRE BRIGADE FOR FUTURE ASSISTANCE AND ADVICE. WHEN THE FIRE IS OUT, HAVE THE FLUE INSPECTED BY A QUALIFIED INSTALLER TO ENSURE THERE HAS NOT BEEN ANY DAMAGE TO THE FLUE SYSTEM.</p>
--

For cleaning the flue, you may purchase a flue brush from your **Coonara** dealer, or you can engage the services of a chimney sweep.

Fan

At the end of the heater season you should clean and vacuum the fan and fan tray. Dust and hair can accumulate, especially if you have a pet.



Turn the mains power off and disconnect the power lead from the wall socket.

Console Models

1. To access the fan on console model, remove the two screws on the left hand and right side of the pedestal cover and put them aside in a safe place.
2. Remove the pedestal cover.
3. This allows easy access to the fan and the fan tray. Thoroughly clean the fan and surrounding components to remove all debris, whilst being careful not to apply undue force on hardware or cabling. A vacuum cleaner with a soft brush fitting is best for this job.
4. Once clean, replace the pedestal cover and tighten screws.
5. Plug the power lead back into the mains wall socket.

Your fan should now be good to go for another season.

Inbuilt Models

At the end of the heater season the fan and fan tray should be cleaned using a vacuum cleaner. Dust and hair can accumulate, especially if you have a pet.

We recommend the use of a qualified service agent to perform fan maintenance for inbuilt models. Accessing the fan involves removal of the door and the fascia surround.

If you wish to conduct this maintenance yourself, please contact Shamic Sheetmetal (Aust) Pty Ltd on phone (03) 9737 5300 for detailed instructions.

Baffle plate removal

The baffle plate is held in place with four locating tabs – 2 either side, front and rear of the firebox.

WARNING: ALLOW THE HEATER TO COOL IF HOT BEFORE ATTEMPTING BAFFLE PLATE REMOVAL.

Cast Iron Baffles

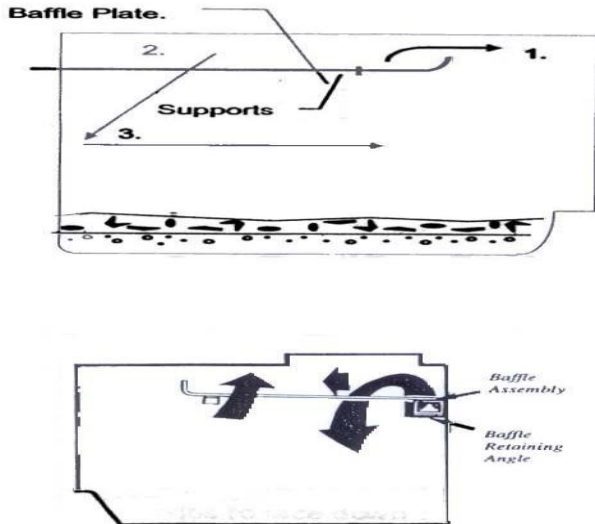

Removal of firebricks may be necessary if fitted.

1. Lift the front of the baffle up and pull forward over the supports until the baffle clears the locating slots in the back wall of the firebox.
2. Lower the rear of the baffle to drop down and rest on the floor of the firebox.
3. Lower the front of the baffle until it clears the support brackets & remove it from the firebox.

DO NOT USE HEATER IF TOP BAFFLE IS DAMAGED

TABLE 1: FIREWOOD SPECIES AND THEIR PROPERTIES

Firewood Species	Forest Type	Heat Avail. Per Unit Volume (%)	Density (Dry Air) lb/ft ³ / Kg/m ³	Splitting	Ignitability	Coals	Sparks	Avail.
Mallee Roots	Mallee	100	N.A	Difficult	Poor	Excellent	Few	Good
Belah, Buloke	Mallee Box-Ironbark	100	70 / 1121	Good	Poor	Excellent	Few	Limited
Grey Box	Box-Ironbark	100	70 / 1121	Difficult	Poor	Excellent	Few	Good
Black Box	Box-Ironbark	97	69 / 1105	Difficult	Poor	Excellent	Few	Limited
Red Ironbark	Box-Ironbark	97	69 / 1105	Difficult	Poor	Excellent	Few	Good
Yellow Box	Box-Ironbark	91	65 / 1041	Difficult	Poor	Excellent	Few	Good
Red Box	Box-Ironbark	91	67 / 1073	Difficult	Poor	Excellent	Few	Good
Yellow Gum	Box-Ironbark	90	60 / 993	Difficult	Poor	Excellent	Few	Good
River Red Gum	River Red Gum	80	56 / 897	Difficult	Poor	Excellent	Moderate	Good
Blue Gum	Foothill	80	61 / 977	Fair	Fair	Good	Few	Good
Red Stringy Bark	Foothill	72	54 / 865	Good	Good	Good	Few	Good
Messmate	Foothill	68	45 / 721	Good	Good	Good	Few	Good
Mountain Ash	Mountain	53	42 / 673	Excellent	Excellent	Fair	Moderate	Good
White Cypress Pine	Box-Ironbark	60	42 / 673	Good	Excellent	Poor	Many	Limited
Radiata Pine	Foothill Plantations	45	32 / 512	Fair	Excellent	Poor	Many	Good

KNOW YOUR WOOD

A piece of dry wood produces an incredible amount of heat when burnt correctly. A piece of dry wood, however is also like a sponge and can absorb up to 70% of its weight in water if exposed to the elements.

The fact that all wood heaters rely on dry fuel to perform at their best, cannot be over-emphasized as it is critical to your heater’s performance. The relevant moisture content (wetness) of wood is indicated in the following table.

Moisture Content	Fuel Suitability
Below 10%	Very dry. Wood burns but less efficiently as some moisture is needed for ideal combustion.
10% - 18%	Ideal. Wood burns efficiently and economically
18% - 25%	Wood will burn, but less efficiently
Above 25 %	Wood too wet to burn efficiently

It is extremely difficult to light, let alone maintain, a fire using wet or green wood. A firebox filled with 20kg, wet or green wood could contain up to 10 litres of water. As a result, the heater would naturally perform very poorly as most of the heat generated would be directed to vaporizing the water. Be aware that if you purchase wood with 50% moisture content, the 50% of the money you paid for the wood, in fact, purchased water.

Ideally, firewood should be organised in the spring and under cover by mid-autumn. If you obtain next year’s wood in spring, it should be open air dried over summer for a minimum of six months. The wood should then be stacked under cover in such a way that air can flow between the pieces. A plastic sheet or tarpaulin is not sufficient as condensation may account for a high moisture content in the wood.

It is important to select firewood that will build a good base or bed of coals. It is actually the coals and not the flames, which form the hottest part of the fire and provide the heat source for your heater.

Dry wood has over twice the density of pine, so double the volume of pine is required to provide the same amount of heat. Firewood that has had the bark removed produces less ash. The table above provides a good indication of the properties of various common type of firewood.

How to Make a Warranty Claim

Coonara, Heatcharm and Arrow Heaters.

The full Warranty Statement for your heater is contained in the Installation and Operating Instructions booklet that was provided with the product.

1. Check the details of the warranty statement
2. Determine if you think the problem is covered by warranty
3. Ensure that you have proof of purchase
4. Contact the retailer that sold you the heater
5. Advise them of the specific problem
6. Provide the details that your retailer requests to complete a Warranty Claim Form. This must include the heater model, serial number and installation compliance certificate, if applicable in your State.
7. Your retailer will forward your claim to Shamic Sheetmetal (Aust) Pty Ltd, the manufacturer of the above heater brands
8. Shamic will contact you to acknowledge that they have received the claim, if the claim has been accepted and the next steps involved in fixing the problem
9. Parts and/or service is provided
10. Contact your retailer if the problem has not been fixed.

SETTLER WOODHEATERS WARRANTY – CONSOLE & INBUILT MODELS

DESIGNATION OF WARRANTOR. This warranty is extended by Shamic Sheetmetal (Aust) Pty. Ltd with respect to SETTLER Woodheaters **PRODUCT.** This SETTLER heater is comprised of the heater proper (including components and firebox), fan assembly, speed control switch, electrical components, firebricks, seals and moving parts. Except where specifically excluded from coverage hereunder, this warranty covers all components designed.

See exclusions and qualifications below for further information on product coverage.

WARRANTY:

- 1) Shamic Sheetmetal (Aust) Pty. Ltd, warrants the firebox to be free of defects in materials and workmanship of a period of ten (10) years from the date of purchase.
- 2) Shamic Sheetmetal (Aust.) Pty.Ltd., warrants that all other components of the unit to be free of defects in material and workmanship for a period of one (1) year from date of purchase, excluding door glass.
- 3) If this SETTLER heater is found to be defective in material or workmanship Shamic will repair or replace such defects in the SETTLER heater at Shamic's option in accordance with SETTLER's warranty policy during the period on this warranty. If the defect is found not to meet the Consumer Guarantee requirements and constitutes a major failure, the purchaser may be able to choose to repair or replace the defective heater or part or obtain a refund.
- 4) Exclusions and qualifications. This warranty is subject to the following exclusions and qualifications.
 - a) This warranty extends only to the original consumer purchaser, who has purchased the heater from an authorised SETTLER dealer.
 - b) This warranty does not apply to, and SETTLER assumes no responsibility for any damages that result due to, installation or operation of the heater not in accordance with both the installation and operation instructions furnished with the unit.
 - c) This Warranty does not cover any damage caused by water from any source.
 - d) This warranty does not apply to any heater, which has been modified or damaged in shipping or by improper handling, improper operation, abuse, misuse, accident or unworkmanlike repairs.
 - e) Shamic Sheetmetal (Aust.) Pty.Ltd. does not warrant the structural performance of the heater when fuel products with abnormal burning characteristics, including but not limited to synthetic logs, coal, wood treated with flammable liquid, logs made from pressed wood, driftwood or any materials containing salt or corrosives, rubbish or garbage are used. Flammable liquid fuels are explosive and should never be used in this product.
 - f) Shamic Sheetmetal (Aust.) Pty.Ltd. Expressly excludes any liability hereunder for defects or damage caused by the installation or of any components not expressly authorised and approved by Shamic. Shamic further assumes no liability for defects or damage caused by any modification not expressly authorised and approved by Shamic. Unauthorised components or modifications could create a fire hazard by altering the safety design of the heater.
 - g) Building Codes. Since building code requirements vary, users should determine in advance whether there are any building code restrictions on the installation or use of the heater. Shamic makes no representation of warranty regarding building code compliance and shall not be responsible for compliance therewith.
 - h) Shamic will only accept claims under this warranty in strict accordance with the conditions set out below.
- 5) Shamic Sheetmetal (Aust.) Pty.Ltd. shall not be liable for any breakages of glass components, transit damage or, where it can be shown that the consumer guarantee obligations as the manufacturer have been met, for any claim by any person for incidental or consequential damages caused by defects in the SETTLER heaters. Whether such damage occurs or is discovered before or after replacement or repair, and whether or not such damage is caused by SETTLER negligence. Normal wear and tear items such as routine surface maintenance, door ropes, seals and door glass are also excluded from this warranty.
- 6) Shamic goods come with guarantees that cannot be excluded under Australian Consumer Law. The purchaser is entitled to a replacement or a refund for a major failure and compensation for any reasonably foreseeable loss or damage. The purchaser is also entitled to have the goods repaired or replaced if the goods fail to be of acceptable quality and the failure does not amount to a major failure.
- 7) This warranty applies only to units purchased from an authorised dealer and the duration of this implied warranty, including merchantability, applicable to this SETTLER heater is limited to the duration of the foregoing warranty.
- 8) Before Shamic Sheetmetal (Aust.) Pty.Ltd. will recognise or accept a claim under this warranty, you must provide proof of purchase. On purchase of the heater, despatch your warranty card to Shamic Sheetmetal (Aust.) Pty.Ltd.
- 9) Your authorised dealer must be notified of any defect in the heater, for investigation of the claim. Your authorised dealer will be able to explain the process of making a warranty claim and any costs associated with returning goods. In the event where a remedy is necessary and the claims under warranty are accepted, the purchaser may be required to return the goods to the authorised dealer for repair, replacement or refund.

DETACH AND RETURN BY MAIL OR EMAIL

WOODHEATER BY SHAMIC SHEETMETAL (AUST) Pty Ltd
PO BOX 8 KILSYTH, VIC. 3136
Ph: 03 9737 5300
Email: info@shamic.com.au



Settler Range

NAME _____

ADDRESS _____

CITY / STATE / POSTCODE _____

PURCHASED AT (Dealer name & address) _____

DATE PURCHASED _____ MODEL _____ SERIAL NO _____

WHERE DID YOU HEAR ABOUT SETTLER WOODHEATERS? RADIO, TELEVISION, NEWSPAPER, DEALER, WEBSITE, OTHER - Please provide details.