



The Warmest Aussie Legend

COONARA “CHATEAU”

HIGH EFFICIENCY GAS LOG SPACE HEATER



CUSTOMER OPERATING INFORMATION & INSTALLATION INSTRUCTIONS

Serial Number of Heater: _____ Model: _____

CHATEAU Gas Heaters ARE AUSTRALIAN OWNED & MANUFACTURED BY

SHAMIC SHEETMETAL (AUST.) PTY. LTD.

PO BOX 8, KILSYTH, VIC. 3136

PH: 03 9737 5300

<https://shamic.co>

WARNING

THE FOLLOWING INSTRUCTIONS MUST BE CARRIED OUT OR WARRANTY BECOMES VOID.

Heater must be installed by an authorized person. You must obtain a license number from the installer.

Heater must be placed on a flat level surface. Inbuilt models must be placed on 6mm AC sheeting, to prevent unit from rattling.

Heater must be checked for scratches or dents prior to installation.

All glass must be fitted with a screw driver not a drill. If glass is broken upon installation due to the screws being tightened too much, it will not be classed under warranty.

Further safety precautions and installation instructions are contained throughout this manual. Please read the manual before installation.

Please read the manual before installation.

CONTENTS

PRODUCT FEATURES _____	4
CUSTOMER OPERATING INSTRUCTIONS _____ SAFETY PRECAUTIONS	6
SAFETY FEATURES _____	7
INSTALLATION INSTRUCTIONS _____	8-11
LOG INSTALLATION & WIRING DIAGRAM _____	12
GAS VALVE ADJUSTMENT _____	13
TROUBLESHOOTING GUIDE _____	14
WARRANTY _____	15-16
CARE OF APPLIANCE _____	17
SERVICE CONTACT INFORMATION _____	19

PRODUCT FEATURES

MODEL - Hermitage, Chateau, Mystique GAS TYPE	NATURAL	L.P.G	Manufacturer
MODEL TYPE GAS INPUT HIGH LOW HEAT OUTPUT HIGH LOW Efficiency Injector Size Manifold Pressure High Low A.G.A Approval No. to Code AS 4553- 2008	Freestanding Inbuilt 33 MJ/h 23 MJ/h 7.6 kW 5.2 kW 78.1 % 2.8 mm 0.9 kPa 0.48 KPa AGA 6165 G	Freestanding Inbuilt 33 MJ/h 23 MJ/h 7.6 kW 5.2 kW 78.1 % 1.7 mm 2.5 kPa 1.3 KPa AGA 6165 G	Shamic Sheetmetal (Aust.) Pty.Ltd. PO BOX 8, KILSYTH, VIC. 3136 To be installed by an authorized person in accordance with installation instructions provided with the appliance.
Electrical Conform to AS3100		240V 50 Hz 120 Watts Max	
Air Pressure Switch		Aria 380 series (5471)	
Cut in Pressure		45 Pa	
Cut out Pressure		40 Pa	
Electrical Connection		Standard Flex. 2 Mt. 3 Pin Plug	

Coonara “Chateau” Inbuilt Gas Log Space Heater

- 33 Mj/h Gas Input Natural Gas and LPG.
- 7.6 kW Output.
- Energy rating **4.6 Stars**
- Electronic ignition.
- Two heat settings.
- External combustion air intake - prevents de-oxygenation of room air.
- Delayed start room fan - prevents cold air being circulated at start-up.
- Delayed stop room fan - aids cool down of unit when switched off.
- Power flue.
- Integrated safety features.

The Coonara “Chateau” Inbuilt model is approved by the Australian Gas Association to Australian Standard AS/NZS 5263.1.3/ Gas Space Heating Appliances.

AGA Approval No. 6165 G.

This appliance shall only be installed in accordance with:

- AS/NZS 5601 (Gas Installation Standard),
- Manufacturer's Installation Instructions,
 - Local Gas Fitting Regulations,
 - Municipal Building Codes.

This appliance **must** only be installed and serviced by an authorised person

Please store this manual in a safe place for future reference

SAFETY PRECAUTIONS



- DO NOT** – OPERATE THIS APPLIANCE BEFORE READING THIS INSTRUCTION MANUAL.
- **DO NOT** – PLACE ARTICLES ON OR AGAINST THIS APPLIANCE.
 - **DO NOT** – STORE CHEMICALS, FLAMMABLE MATERIALS OR SPRAY AEROSOLS NEAR THIS APPLIANCE
 - **DO NOT** – OPERATE WITH PANELS, COVERS OR GUARDS REMOVED FROM THIS APPLIANCE.
 - **DO NOT** – ENCLOSE THIS APPLIANCE.
 - **DO NOT** – MODIFY THIS APPLIANCE.
 - **DO NOT** – PLACE ANY ITEM CONTAINING LIQUID ON THE APPLIANCE
 - **ALWAYS** – SUPERVISE YOUNG CHILDREN NEAR THE APPLIANCE

Note: In the event that the electricity supply cord is damaged it must be replaced with Coonara part # 6306, obtainable from authorised gas retailers.

SAFETY GUARD

THE SAFETY GUARD IN THE GLASS DOOR IS FITTED TO THIS APPLIANCE TO REDUCE THE RISK OF FIRE OR INJURY FROM BURNS. NO PART OF IT SHOULD BE PERMANENTLY REMOVED. IF HEATER IS DAMAGED DURING REMOVAL OF SAFETY GUARD, DAMAGE WILL NOT BE COVERED BY WARRANTY.

FOR PROTECTION OF YOUNG CHILDREN OR THE INFIRMED, A SECONDARY GUARD IS REQUIRED.

INSTALLATION

THIS APPLIANCE SHALL ONLY BE INSTALLED BY AN AUTHORISED PERSON

IN ACCORDANCE WITH ASNZS 5601 (GAS INSTALLATION STANDARD),

MANUFACTURERS INSTALLATION INSTRUCTIONS,

LOCAL GAS FITTING REGULATIONS AND MUNICIPAL BUILDING CODES.

CUSTOMER OPERATING INSTRUCTIONS

The Coonara “Chateau” Gas Log Space Heater has been designed for simple efficient operation, with only two switches for ignition and both High and Low settings.

PRE-OPERATION CHECKS

Prior to operating the heater, ensure that the flue terminal is not obstructed. Furthermore, make sure there are no combustible objects leaning against, resting on, or within the immediate vicinity of the unit. Check that the heater main power and gas supply are connected and switched on.

OPERATING THE HEATER

The heater controls for the Chateau inbuilt model are located on the top front right hand fascia.

To operate the heater, press the smaller of the two switches labeled On/Off to the “On” position, the electronic control will commence a safety check period of approximately 8 seconds prior to igniting the heater. The room fan will start operating once the appliance has begun to heat-up, thus preventing cold air circulation.

To operate on High fire/High fan mode, set the larger switch to the “High” position. When the area to be heated has reached a comfortable temperature level set the switch to the “Low” position.

The heater may be switched on or off, in either the High or Low settings.

To operate the heater using the Thermostat please refer to the “8000 Series Thermostat User Manual” for further information.

Note: At start up, if the “High” position has been selected the heater will only ignite on the “Low” setting and will automatically switch to the “High” setting after an initial warm up period.

TURNING THE APPLIANCE OFF

Set the smaller of the two switches to the “Off” position.

The room fan will continue to operate for a short period while the heater cools down.

To turn the heater off using the Thermostat please refer to the “7000 Series Thermostat User Manual” for further information.

Note 1: This appliance cannot be operated without the fan operating.

Note 2: Due to the performance and efficiency of the heater, steam may be noticed coming from the flue terminal on days of low temperature.

Note 3: As this appliance has a luminous flame effect some slight carbon depositions may occur.

Note 4: During first time firing of this appliance, an odour may be noticed for a short period as the paint cures. It is advisable to leave a window open during the first few hours of the very first operation only.

SAFETY PRECAUTIONS

IMPORTANT POINTS

- ! **DO NOT** place articles or clothing on or against this appliance.
- ! **DO NOT** use or store flammable materials near this heater.
- ! **DO NOT** place any item containing liquid on the heater.
- ! **DO NOT** spray aerosols in the vicinity of this appliance when it is in operation.
- ! **DO NOT** modify this appliance.
- ! **ALWAYS** supervise young children near the appliance.

It is recommended that a secondary guard be used, to prevent access to appliance by children, as outer panels of this appliance may reach high temperatures.

Note: In the event that the electricity supply cord is damaged it must be replaced with Coonara part # 6306, obtainable from authorised gas retailers

PRIMARY GUARD

A primary guard is fitted to this appliance to reduce the risk of fire or injury from burns and no part of it should be removed. For protection of young children or the infirm, a secondary guard is required.

SAFETY FEATURES

Automatic Shut-Off: Should the flame extinguish for any reason, there is an automatic close off of the gas supply.

Note: fans will continue to operate as normal.

Over Temperature Protection: In the event of the room fan failing, blockage of airways, or incorrect gas installation, the gas supply will be automatically closed off to prevent the appliance over-heating.

Record the following information in the space provided.

Purchased from:

Name _____

Address _____

Phone No _____ Date of purchase _____

Model of Appliance _____ Serial No _____

To be completed by installer:

Name _____ License No _____

Address _____

Phone No _____ Date installed _____

Note: This appliance can only be installed by an authorized person who is responsible for its correct operation at the time of installation.

AS/NZS 5601 Appliance Commissioning

9.2 The commissioning of an appliance shall take full account of special design features, the manufacturer's instructions and the appliance safety requirements.

9.3 the commissioning of an appliance shall include all of the following

- (a) Compliance with clauses 2.4.2 and 2.6
- (b) The appliance is to be checked to ensure safe working order.
- (c) The burner of the appliance is to be lit and where necessary adjusted, in accordance with the manufacturer's instructions
- (d) The consumer, where available, is to be instructed on the safe and correct operation of the appliance and any auxiliary equipment.
- (e) The appliance operating instructions are to be handed to the consumer, or if the consumer is not present, the instructions are to be left in a suitable location on the premises.

WARNING

**Heater must be checked for scratches or dents prior to installation. Once the Heater is installed scratches or dents are not covered by warranty.
Must be placed on a flat level surface to prevent rattles**

INSTALLATION

Inbuilt Model

Only to be carried out by an authorised person!

6mm Cement Sheeting required for floor installation.

1. Carefully remove the carton from the heater, - remove heater & flue kit from pallet.
 2. Remove wire guard. Lift up and pull forward
 3. Remove the 2 screws holding the fascia surround to the firebox body. This surround is located by 2 lugs, and is removed by lifting upwards approximately 5 mm then forward.
 4. Remove the 2 screws under the Glass Surround and lift up glass Surround
 5. **Check** the label on the rear of the firebox to confirm gas type is appropriate for the gas supply available
 6. Loosen the lower glass retaining bracket screws. Completely remove the top glass retaining bracket. - Remove the glass.
 7. Unpack the log set from their separate carton and position them in the firebox as shown in the diagram on Page 13.
 8. Install the flue – see. Inbuilt Model – Flue installation Pages 8 - 12.
 9. Locate the heater body into the fireplace cavity, or pre-built wall cavity. Connect the gas supply, purge gas lines, check all connections for leaks, check pressures (refer to pressure settings on page 14) and adjust if necessary.
 10. Fix the appliance firmly in position using the 4 angle brackets fixed to the heater body
 11. Connect the air inlet and exhaust pipes to the outlets on the heater body.
- NOTE – The EXHAUST flue is colour coded RED at the heater body, both ends of the flue pipe and at the collector box on the flue terminal assembly
12. Re-assemble heater in reverse order of above. Connect electrical cord to correctly wired and earthed 240 Volt AC power point.
 13. Operate heater, check operation on both, Hi and Low settings. Ensure fan operates after initial warm-up period. (Refer Trouble Shooting Guide page 15 should any problems occur.)

Instruct customer of correct operating procedure.

VERTICAL FLUE INSTALLATION

INBUILT MODEL

1. Connect flue terminal to both flexible flue pipes. The exhaust pipe is colour coded RED at each end, the exhaust outlet on the heater body and the exhaust port at the flue terminal.
2. Feed both flexible pipes down the flue cavity.
3. Fix flue terminal securely to top of flue cavity and seal to prevent water entry. Seal with Hi Temperature waterproof silicon sealant prior to cementing to chimney top, pop rivet circular flange to base of collector box. (Chimney installation only).
4. Connect flexible flue pipes to the correct outlet at the heater body Exhaust being colour RED

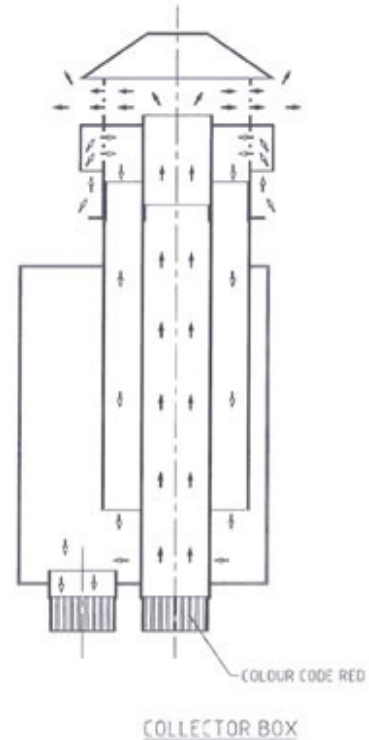
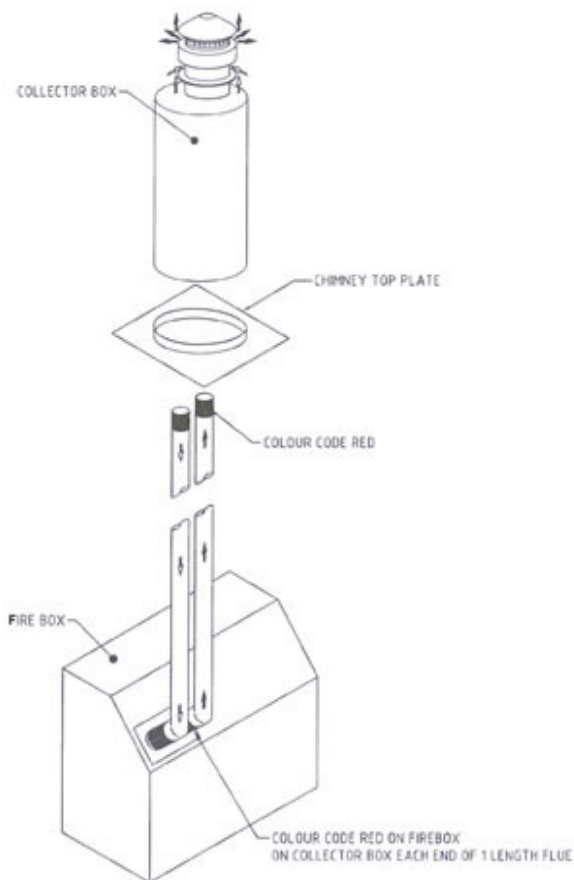

Manufactured by SHAMIC SHEETMETAL (Aust.) Pty. Ltd.

INBUILT MODEL

Rear vent Flue Installation

1. Determine the exact location for the heater.
2. Mark the exact location for the wall penetration
 - a. Determine that you will not be cutting through any vertical wall studs.
 - b. Check that the location of the wall-mounted terminal conforms to the requirements of AS/NZS 5601 – Location of a Flue Terminal.
3. Cut 2 holes 95mm in diameter at 100mm centres holes to be side by side in the horizontal.
4. Use the back of the cowl as a template for fixing holes.
5. Fit flex flue to spigots on the rear of the cowl using provided hose clamps and seal with silicone.
NOTE- it may be necessary to trim the flue depending on wall thickness.
6. Attach the back of the cowl to the wall. Silicone around outside.

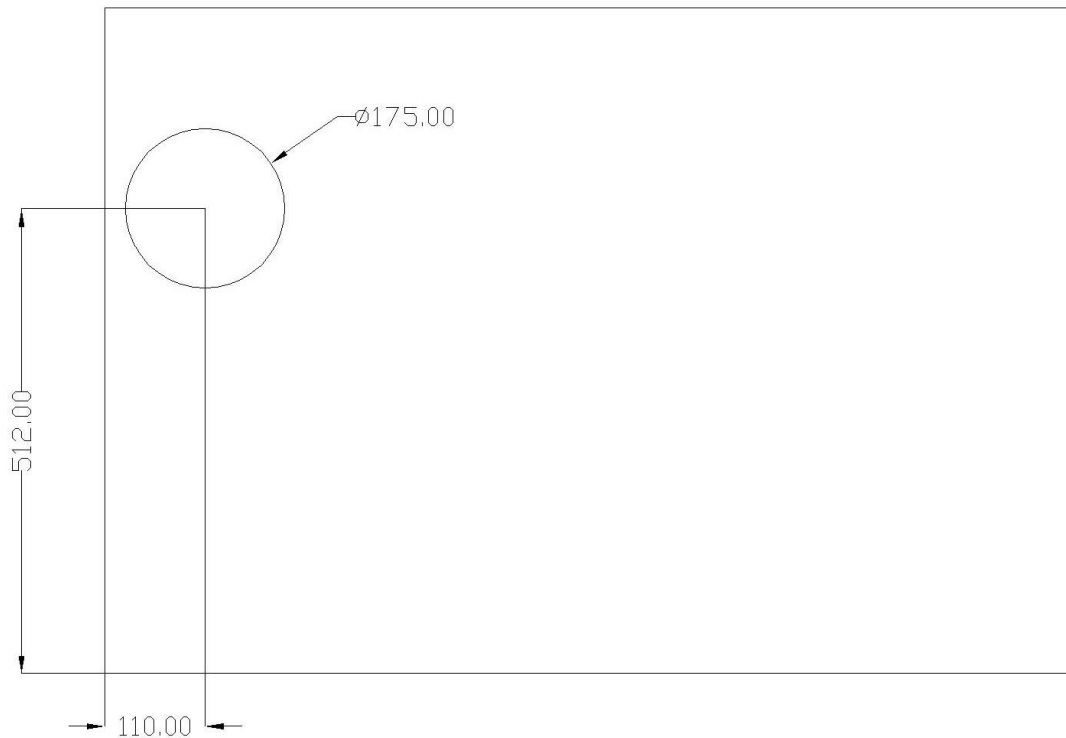

Fig 1:Rear of heater showing exact location of flue (shown from rear).

Installation in a Stud wall cavity.

1. Mark the exact location of where the heater is to be located with an outline 720mm wide by 615mm high
2. Check that location for the flue terminal conforms to the requirements of AS/NZS 5601 Location of a Flue Terminal.
3. Cut out the plaster board and timber supports (re-position supports if necessary)
4. Refer to figure 1, and continue as described on previous page.
5. When completed, fit the “console cover” supplied to the heater fascia surround. Fit to the heater body. Attach heater fascia.

Installation through the wall.

1. Mark the exact location of where the heater is to be located with an outline 720mm wide by 615mm high.
2. Check that location for the flue terminal conforms to the requirements of AS/NZS 5601 location of a Flue Terminal.
3. Cut out the plaster board and timber supports (re-position if necessary) cut out the outer brickwork.
4. Feed the gas line through the hole located at the lower right hand side of the outer weather cover (provided) and the flue pipes through the pre-punched hole for the flue pipes on the upper left hand side.
5. Locate the appliance, connect gas.
6. Fit the outer weather cover over the exposed heater body and screw to the outer wall. Also use a silicon sealant.
7. Fit the cowl backing plate to the outer weather cover (Also use a silicon sealant).
8. Fit the cowl to the flue pipes and then to the cowl mounting plate.
9. Firmly fix the appliance in to position using the brackets on each side of the heater casing.
10. Replace fascia surround and Fascia.

External weather cover assembly/installation.

The weather cover is supplied partially assembled with only the base panel to be attached to complete the assembly (screws provided).

There is a moveable cover plate at the lower right hand of the rear panel for fitment of the gas connection.

The horizontal cowl mounting plate (which is common for both full and partial wall penetrations) has a total of 8 pre-drilled holes. For attachment to the external weather cover the 4 inner 4.5 mm holes are utilized (screws provided). When attached to masonry or weatherboard the 4 outer 6mm holes are utilized.

Note: when the weather cover and cowl are attached it is necessary to seal the top and side edges with silicone to prevent water entry.

IMPORTANT !
The Chateau Gas Log Heater
must always be vented to the outside !

INSTALLATION OF LOG SET

1. Place the rear log on the rear of the burner plate as shown.
2. Place front log on the front section of the burner.
3. Fit the cross logs (as illustrated below) to the pins located on the front and rear logs
4. The small logs supplied are for fitting into the gaps in the front corners of the burner assembly. Care should be taken not to place these over the burner holes. Logs should not touch the sensor or sparker.



Above diagram shows correct orientation of logs

WIRING DIAGRAM

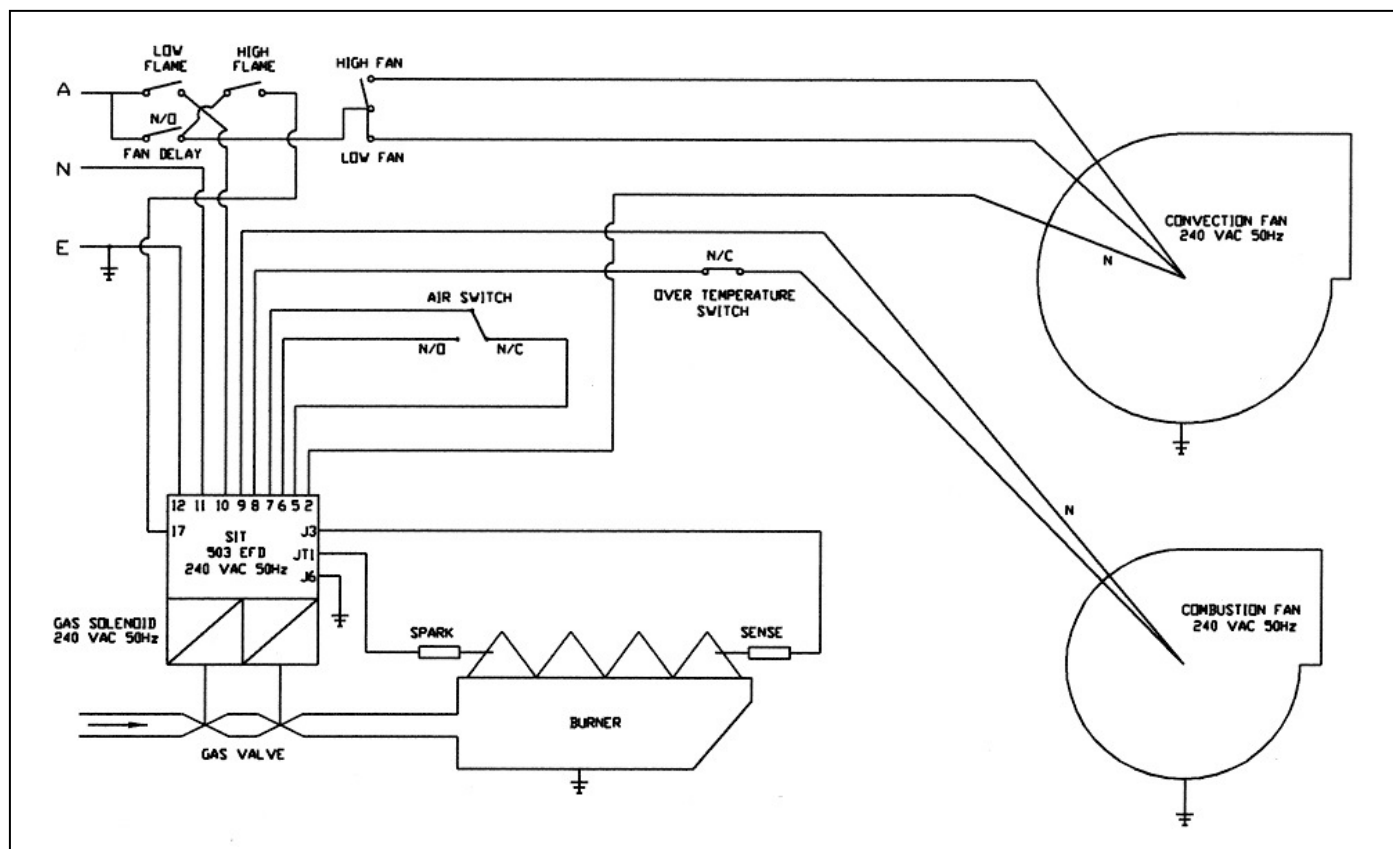

CHATEAU GAS VALVE

SIT 843

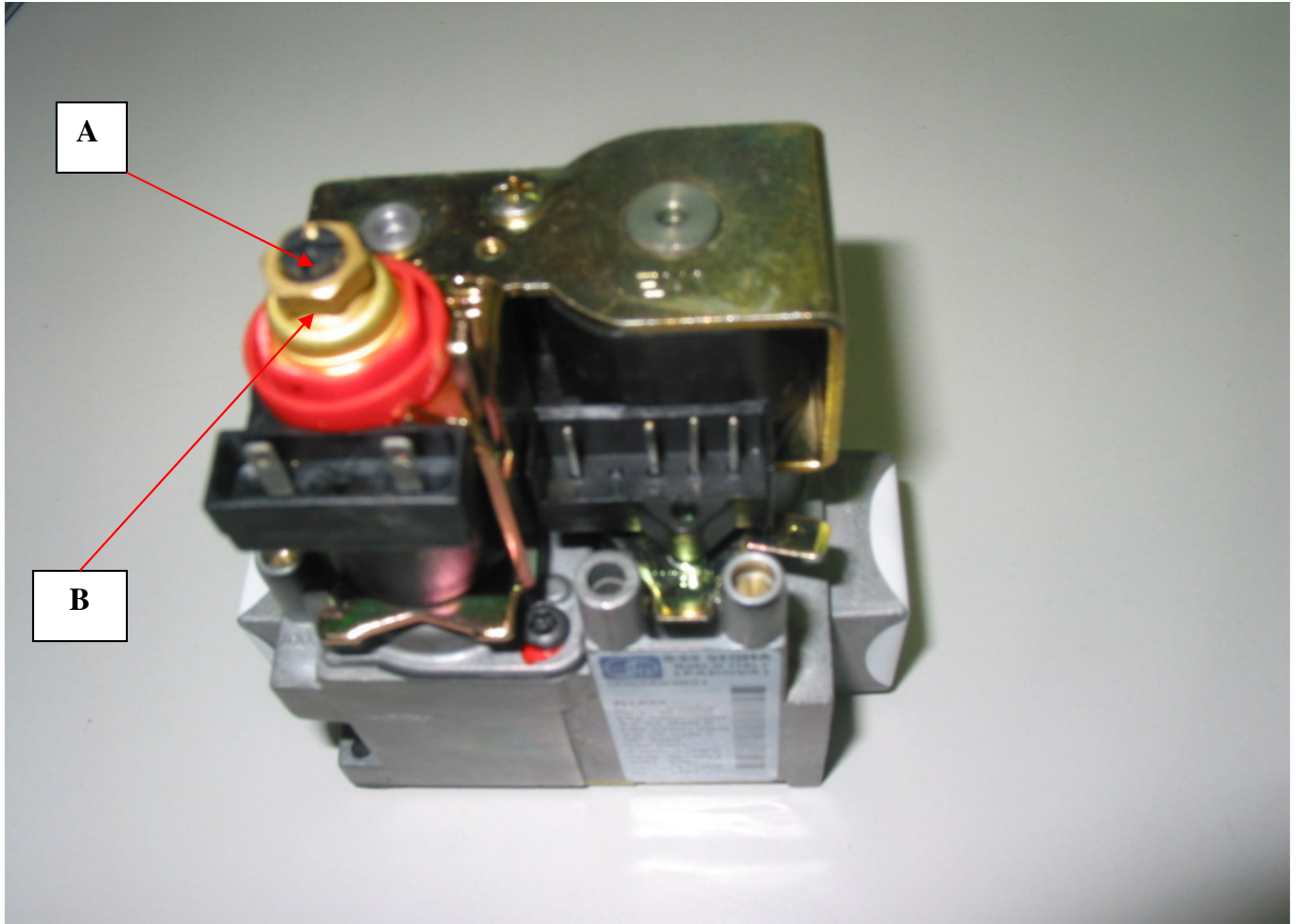

“A” represents the low gas adjustment. Turn the screw clockwise to increase gas pressure.

“B” represents the high gas adjustment. Turn the nut clockwise to increase gas pressure.

Natural Gas

Burner test point pressure –

HIGH **0.9 kPa**, LOW **0.48 kPa**

Primary air shutter adjustment –

fully open

Natural gas injector orifice –

2.8mm diameter

LPG Gas

Burner test point pressure-

HIGH **2.50 kPa**, LOW **1.30 kPa**

Primary air shutter adjustment –

fully open

Propane gas injector orifice –

1.7 mm diameter

TROUBLESHOOTING GUIDE

PROBLEM	POSSIBLE CAUSE	REMEDY
Appliance fails to ignite.	<p>No gas or supply pressure insufficient.</p> <p>No electrical supply.</p> <p>Incorrectly wired power point.</p> <p>Incorrect gas valve adjustment.</p> <p>Insufficient time allowed between attempts.</p> <p>Internal wiring disconnected.</p>	<p>Ensure gas supply connected, purged, and pressure appropriate.</p> <p>Ensure unit plugged in and switch is on, check supply fuse.</p> <p>Check supply. Active, neutral, & earth must be correctly orientated and connected.</p> <p>Adjust valve pressures.</p> <p>Wait at least 15 seconds for unit to purge combustion chamber after switching on.</p> <p>Check all plugs inside appliance are connected properly and correctly located, Ensure operation of combustion fan & air pressure switch.</p>
Unit will not operate on Low.	<p>Incorrect gas valve adjustment.</p> <p>Incorrect or loose wiring.</p>	<p>Adjust valve.</p> <p>Check wiring.</p>
Room fan not operating.	<p>Insufficient time allowed.</p> <p>Loose wiring.</p> <p>Fan not located correctly.</p> <p>Fan blocked.</p>	<p>Fan has a delayed start and will not start until unit warms-up.</p> <p>Check wiring.</p> <p>Install fan in correct location.</p> <p>Remove and clean fan.</p>
Unit cuts out after a period of time then cycles on and off.	<p>See "Room fan not operating"</p> <p>Heat exchanger blockage.</p> <p>Excessive pressure or incorrect gas type.</p>	<p>See "Room fan not operating"</p> <p>Clean heat exchanger.</p> <p>Ensure correct gas type, injector size, and pressure setting.</p>
Excessive carbon (soot) deposits on inside of firebox, logs, and/or glass.	<p>Incorrect gas type or pressure setting.</p> <p>Primary air shutter incorrectly adjusted for gas type.</p>	<p>Ensure correct gas type, injector size, and pressure setting.</p> <p>Adjust primary air shutter.</p>
Excessive flame height.	<p>Incorrect gas type or pressure setting.</p>	<p>Ensure correct gas type, injector size, and pressure setting.</p>
Excessive flame "lift off"	<p>Flue or inlet blockage.</p> <p>Recirculation of flue gases.</p>	<p>Clear blockage.</p> <p>Flue incorrectly installed.</p>
Unit fails to heat.	<p>See "Room fan not operating"</p> <p>Incorrect gas type or pressure setting.</p> <p>Gas supply blockage.</p>	<p>See "Room fan not operating"</p> <p>Ensure correct gas type, injector size, and pressure setting.</p> <p>Check injector, burner supply pipe, & valve for foreign matter.</p>

All service work to be carried out by a qualified & authorised person.

How to Make a Warranty Claim

Coonara, Heatcharm, Arrow and Settler Heaters.

The full Warranty Statement for your heater is contained in the Installation and Operating Instructions booklet that was provided with the product.

1. Check the details of the warranty statement
2. Determine if you think the problem is covered by warranty
3. Ensure that you have proof of purchase
4. Contact the retailer that sold you the heater
5. Advise them of the specific problem
6. Provide the details that your retailer requests to complete a Warranty Claim Form. This must include the heater model, serial number and installation compliance certificate, if applicable in your State.
7. Your retailer will forward your claim to Shamic Sheetmetal (Aust) Pty Ltd, the manufacturer of the above heater brands
8. Shamic will contact you to acknowledge that they have received the claim, if the claim has been accepted and the next steps involved in fixing the problem
9. Parts and/or service is provided
10. Contact your retailer if the problem has not been fixed.

WARRANTY

DESIGNATION OF WARRANTOR. This warranty is extended by Shamic Sheetmetal (Aust) Pty. Ltd with respect to Coonara gas heaters

PRODUCT. This Coonara gas heater is comprised of the heater proper (including components and firebox), fan assembly, speed control switch, electrical components, gas valves, seals and moving parts. Except where specifically excluded from coverage hereunder, this warranty covers all components designed.

See exclusions and qualifications below for further information on product coverage.

WARRANTY:

- 1) Shamic Sheetmetal (Aust) Pty. Ltd, warrants the firebox and the heat exchanger to be free of defects in materials and workmanship of a period of five (5) years from the date of purchase.
- 2) Shamic Sheetmetal (Aust.) Pty.Ltd., warrants that all other components of the unit to be free of defects in material and workmanship for a period of two (2) years from date of purchase, excluding door glass.
- 3) If this Coonara heater is found to be defective in material or workmanship Shamic will repair or replace such defects in the Coonara heater at Shamic's option in accordance with Coonara's warranty policy during the period on this warranty. If the defect is found not to meet the Consumer Guarantee requirements and constitutes a major failure, the purchaser may be able to choose to repair or replace the defective heater or part or obtain a refund
- 4) Exclusions and qualifications. This warranty is subject to the following exclusions and qualifications.
 - a) This warranty extends only to the original consumer purchaser, who has purchased the heater from an authorised Coonara dealer.
 - b) This warranty does not apply to, and Coonara assumes no responsibility for any damages that result due to, installation or operation of the heater not in accordance with both the installation and operation instructions furnished with the unit.
 - c) This warranty does not apply to any heater which has been modified or damaged in shipping or by improper handling, improper operation, abuse, misuse, accident or unworkmanlike repairs.

- d) Shamic Sheetmetal (Aust.) Pty.Ltd. does not warrant the structural performance of the heater when fuel products other than the specified gas fuels are used. Flammable liquid fuels are explosive and should never be used in this product.
 - e) Shamic Sheetmetal (Aust.) Pty.Ltd. expressly excludes any liability hereunder for defects or damage caused by the installation or of any components not expressly authorised and approved by Shamic. Shamic further assumes no liability for defects or damage caused by any modification not expressly authorised and approved by Shamic. Unauthorised components or modifications could create a fire hazard by altering the safety design of the heater.
 - f) Building Codes. Since building code requirements vary, users should determine in advance whether there are any building code restrictions on the installation or use of the heater. Shamic makes no representation of warranty regarding building code compliance and shall not be responsible for compliance therewith.
 - g) Shamic will only accept claims under this warranty in strict accordance with the conditions set out below.
- 5) Shamic Sheetmetal (Aust.) Pty.Ltd. shall not be liable for any breakages of glass and log components, transit damage or, where it can be shown that the Consumer Guarantee obligations have been met, for any claim by any person for incidental or consequential damages caused by defects in the Coonara heater. Whether such damage occurs or is discovered before or after replacement or repair, and whether or not such damage is caused by Coonara negligence. Normal wear and tear items such as routine surface maintenance, seals and door glass are also excluded from this warranty.
- 6) Shamic goods come with guarantees that cannot be excluded under Australian Consumer Law. The purchaser is entitled to a replacement or a refund for a major failure and compensation for any reasonably foreseeable loss or damage. The purchaser is also entitled to have the goods repaired or replaced if the goods fail to be of acceptable quality and the failure does not amount to a major failure.
- 7) This warranty applies only to units purchased from an authorised dealer and the duration of this implied warranty, including merchantability, applicable to this Coonara heater is limited to the duration of the foregoing warranty.
- 8) Before Shamic Sheetmetal (Aust.) Pty.Ltd. will recognise or accept a claim under this warranty, you must provide proof of purchase. On purchase of the heater, despatch your warranty card to Shamic Sheetmetal (Aust.) Pty.Ltd.
- 9) Your authorised dealer must be notified of any defect in the heater, for investigation of the claim. Your authorised dealer will be able to explain the process of making a warranty claim and any costs associated with returning goods. In the event where a remedy is necessary and the claims under warranty are accepted, the purchaser may be required to return the goods to the authorised dealer for repair, replacement or refund.

CARE OF YOUR “CHATEAU” GAS HEATER

This appliance requires minimal maintenance; however, it is recommended that a full service and check be made by a qualified person annually.

The fascia should be removed and the fan vacuumed annually.

To clean the appliance, simply wipe over with a damp cloth. **Do not use solvents or abrasive cleaning agents.**

Before calling for service, check that:

- ! Electrical power is switched on,
- ! Gas is turned on,
- ! There are no obstructions/blockages of the flue terminal.

This appliance incorporates a live fuel effect and is designed to operate with luminous flames. The appliance may exhibit slight carbon deposit (sooting). Refer to the Troubleshooting Guide on page 15 for instructions relating to cases of excessive carbon deposit.



The Warmest Aussie Legend

For your nearest authorised service company, please contact:

SHAMIC SHEETMETAL (AUST.) PTY. LTD.

14 – 18 Research Drive, CROYDON SOUTH, VIC. 3136

POSTAL ADDRESS:

P.O. Box 8, KILSYTH, VIC. 3137

Phone: (03) 9737 5300

Email: info@shamic.com.au



DETACH AND RETURN BY MAIL



NAME _____

ADDRESS _____

CITY / STATE / POSTCODE _____

PURCHASED AT (Dealer name & address) _____

DATE PURCHASED _____ MODEL _____ SERIAL NO _____

WHERE DID YOU HEAR ABOUT CHATEAU GAS HEATERS?

RADIO, TELEVISION, NEWSPAPER, DEALER, WEBSITE, OTHER – please provide details.